

FI.ICT-2011.1.8 FINESCE

D7.7 v1.0

Consolidated FINESCE API and Handbook

Contractual Date of Delivery to the CEC: February 28 2015

Actual Date of Delivery to the CEC:

Author(s): Artemis Voulkidis, Theodore Zahariadis

Participant(s): SYN

Workpackage: *WP6 – FI in Energy Business Innovation*

Estimated person months: 4

Security: PU

Nature: R = Report

Version: 1.0

Total number of pages: 181

Abstract:

The Consolidated FINESCE API and Handbook overviews and documents the FINESCE API specification. The set of services provided by the FINESE trials to interested parties and in particular the FI-PPP Phase III projects are presented and explained. The goal of this handbook is to provide a complete, consistent and homogenous overview of the FINESCE API in order to facilitate exploitation from third parties and allow for building smart energy ecosystems on top of the FI-enabled FINESCE trial infrastructures.

Keyword list:

API, Trial sites, Service, RESTful, JSON, XML, Building Management System, Demand Side Management, Demand Side Response, Distributed Energy Resources, End-user engagement, Electric Vehicles, Measurements, Marketplace, Metering, Microgrid

Disclaimer:

All information provided reflects the current status of the FINESCE API at the time of writing and may be subject to change.

All intellectual property rights are owned by the FINESCE consortium members and are protected by the applicable laws. Except where otherwise specified, all document contents are: "© FINESCE project -All rights reserved". Reproduction is not authorised without prior written agreement. All FINESCE consortium members have agreed to full publication of this document. The commercial use of any information contained in this document may require a license from

the owner of that information. All FINESCE consortium members are also committed to publish accurate and up to date information and take the greatest care to do so. However, the FINESCE consortium members cannot accept liability for any inaccuracies or omissions nor do they accept liability for any direct, indirect, special, consequential or other losses or damages of any kind arising out of the use of this information.

Executive Summary

FINESCE, composed of seven distinct trials, exposes a multitude of services addressing a variety of topics related to smart energy grids and systems, in general. The diversity of the various FINESCE trials' scopes has allowed for successfully capturing the requirements for effective and efficient smart energy systems operation. Considering the rapid evolution of the Smart City concepts and the need for direct integration with Smart Energy systems for reasons of sustainability, a framework to expedite such an integration is the actual cause of the FINESCE platform and API.

The consolidated FINESCE API and Handbook classifies and presents the FINESCE trial services APIs, also detailing them in order to highlight their hierarchical structure and hide the internal trial infrastructures complexity from third parties. Due to its open nature, the FINESCE API specification will allow third parties to easily experiment with the FINESCE trials and take full advantage of their capabilities, in an attempt to render feasible the foundation of a business-ready ecosystem of FINESCE-based smart energy added-value services. In the context of FI-PPP continuity, the FINESCE API will allow for Phase-III energy-related projects to develop with ease novel business models and applications, using data and expertise deriving from the FINESCE trials and consortium members, respectively. In the context of a more general Smart City ecosystem embracing Smart Energy capabilities, the FINESCE API could serve as a guide for developers to develop applications and services that expose FINESCE-compliant APIs and, combined with the FINESCE API Mediator DSE, directly integrate them with well tested services and infrastructures provided by FINESCE trials.

In this framework, a number of related application aspects have been identified by the FINESCE consortium members that necessitate the emersion of services handling and giving access to information among others related to (a) building and electric vehicles monitoring and control systems, (b) demand response and pricing management operations, (c) smart grid energy power/energy monitoring, (d) smart factories and (f) virtual power plants. As the relevant application domains often necessitate the exposure of similar information services, a classification of the latter has been attempted and is thoroughly documented. Since all FINESCE trials expose RESTful interfaces, the documentation focuses on the determination of the various parameters that should be defined to invoke the services in a meaningful way. Moreover, it provides an in depth view of the expected service responses, uncovering the common FINESCE API data representation format and providing examples of usage.

Authors

Partner	Name	Phone / Fax / e-mail
Synelixis Solutions Ltd.		
	Artemis Voulkidis	Phone: +30 210 2511584 e-mail: voulkidis@synelixis.com
	Theodore Zahariadis	Phone: +30 210 2511584 e-mail: zahariad@synelixis.com

Table of Contents

1	Preface	12
1.1	About this document	12
1.2	Who should read this document	12
1.3	How should this document be read	12
1.4	Legal Notice	14
1.5	FINESCE data availability and further exploitation	14
2	FINESCE API Specification	15
2.1	Authentication	17
2.1.1	Authenticate a user	17
2.1.2	Refresh a token	18
2.2	Building information	20
2.2.1	Get list of buildings in trial	20
2.2.2	Get building Description	22
2.2.3	Get available measurement types for a specific building	23
2.2.4	Get the available measurement types for the trial	24
2.2.5	Get the available measurement types for the trial, based on their id.....	25
2.2.6	Get the available measurement types for buildings, based on their type	26
2.2.7	Get the available measurements for a specific building.....	27
2.2.8	Get the available building components/modules	30
2.2.9	Get the status of a building component/module.....	31
2.2.10	Get the available building zones	32
2.2.11	Get the available measurements of a building zone	34
2.3	Demand Response	36
2.3.1	Get the list of issue resolution plans sharing a common author	36
2.3.2	Get the list of issue resolution plans sharing a common state.....	38
2.3.3	Get the list of issue resolution plans sharing common authors and states	40
2.3.4	Get the list of incentive plans sharing a common author	42
2.3.5	Get the list of incentive plans sharing a common state.....	45
2.3.6	Get the list of incentive plans sharing common authors and states.....	47
2.3.7	Get the contracts corresponding to a customer, regardless of their state	49
2.3.8	Get the contracts corresponding to a customer, characterized by a specific state.....	50
2.3.9	Get the contracts corresponding to a customer, characterized by a specific state.....	51
2.3.10	Get the user-contracted energy prices.....	52
2.4	Discrete Time Support	55
2.4.1	Get the available timeslots	55
2.4.2	Get a timeslots based on its id	56
2.4.3	Get the algorithmic weights associated with a timeslot, based on its id	57
2.4.4	Get the charging states associated with a timeslot, based on its id	59
2.4.5	Get the EVSE energy records associated with a timeslot, based on its id	61
2.5	Energy demand / Power consumption.....	62
2.5.1	Get the energy consumption profile of a sector	62
2.5.2	Get the energy consumption profile of a user	64
2.5.3	Get the total energy consumption of a user	65
2.5.4	Get the power demand of a user.....	67
2.6	Energy supply / Power production	68
2.6.1	Get the energy production profile of a sector	68
2.6.2	Get the energy production profile of a user.....	69
2.6.3	Get the total energy production of a user	71
2.6.4	Get the power supply of a user	72
2.6.5	Get the power supply of a building module	73
2.6.6	Get the total power of a building module.....	74
2.7	Electric Vehicles.....	76
2.7.1	Get the list of vehicles in trial	76
2.7.2	Get vehicle Description	77
2.7.3	Get vehicles measurement types.....	78
2.7.4	Get vehicles measurement types based on their id	80

2.7.5	Get vehicles measurement types based on their general type	81
2.7.6	Get the available measurement types of a single vehicle	81
2.7.7	Get the measurements of a single vehicle	82
2.7.8	Get the connections of an EV with an electric vehicle supply equipment component	84
2.7.9	Get the supported electric vehicle types	86
2.7.10	Get a specific electric vehicle type description, based on its id	87
2.7.11	Get the electric vehicles sharing a common type, based on its id	88
2.7.12	Get the EVs charging modes	89
2.7.13	Get a charging mode based on an id	91
2.7.14	Get the electric vehicle supply equipment components related to a charging mode	92
2.7.15	Get the EV types related to a charging mode	94
2.7.16	Get the electric vehicle charging states	94
2.7.17	Get an EV charging state based on its id	96
2.7.18	Get the available EVSE connections	97
2.7.19	Get an EVSE connection based on its id	98
2.7.20	Get an EVSE charging mode based on a connection id	99
2.7.21	Get an EVSE connection state based on a connection id	100
2.7.22	Get the available EVSEs connection states	101
2.7.23	Get an EVSE connection state through its id	102
2.7.24	Get all the electric vehicle supply equipment components available	103
2.7.25	Get an electric vehicle supply equipment component, based on its id	104
2.7.26	Get the charging modes associated with an electric vehicle supply equipment component, based on its id	105
2.7.27	Get the connections associated with an electric vehicle supply equipment component, based on its id	106
2.8	External information	108
2.8.1	Get the latest known social events	108
2.8.2	Get a specific number of the latest known social events	110
2.9	Metering infrastructure details	112
2.9.1	Get the list of all meters	112
2.9.2	Get a specific meter description	114
2.9.3	Get the list of all available sectors	115
2.10	Optimization	117
2.10.1	List available algorithm weights	117
2.10.2	Get an algorithm weight object based on its id	118
2.11	Pricing	119
2.11.1	Get the available energy prices in a trial	119
2.11.2	Get the available energy prices in a trial within a time range	120
2.11.3	Get the available energy prices in a trial location, based on its name	122
2.11.4	Get the available energy prices within a time range in a trial location, based on its name	123
2.11.5	Get the price locations available to the user	125
2.11.6	Get a price location based on its name	127
2.11.7	Get a data stream for all the available pricing locations	128
2.11.8	Get a data stream for a specific pricing location	129
2.11.9	Get a data stream for a specific pricing location, for a specific period of time	130
2.12	Regional Energy-Related Information	133
2.12.1	Get the available regions	133
2.12.2	Get a region based on its ID	134
2.12.3	Get the algorithmic optimization weights associated with a region	135
2.12.4	Get an energy report associated with a region	136
2.12.5	Get an average energy report associated with a region	137
2.12.6	Get the EVSE entities associated with a region	138
2.12.7	Get the energy status of the trial regions	139
2.12.8	Get the energy status of a region	141
2.12.9	Get a region associated with a regional energy record	142
2.12.10	Get a timeslot associated with a regional energy record	142
2.12.11	Get the average EVSE regional energy records	143
2.12.12	Get an average EVSE regional energy record	144
2.13	Simulation	146

2.13.1	Get prediction of user power demand	146
2.13.2	Get prediction of sector power demand	147
2.13.3	Get prediction of user power supply	149
2.13.4	Get prediction of sector power supply	150
2.14	Smart Factories	152
2.14.1	Get available machines	152
2.14.2	Get information over a single machine	153
2.15	Virtual Power Plant	157
2.15.1	Get VPP components data	157
2.15.2	Get the data of a specific VPP component	159
2.15.3	Get the measurements of a specific VPP component in a day	161
2.15.4	Get the predictions for a specific VPP component in a day	163
2.16	Weather forecast	165
2.16.1	Get available forecast descriptors	165
2.16.2	Get detailed weather report	167
2.16.3	Get detailed weather report	171
2.16.4	Get detailed weather report (limited records)	172
3	Conclusion	175
4	References	176
5	List of Abbreviations	177
6	Appendix A – Summary of the FINESCE API services exposed by the FINESCE API Mediator	178
6.1	Aachen Trial – Smart Factory	178
6.2	Aachen Trial – Virtual Power Plant	178
6.3	Horsens Trial	178
6.4	Ireland Trial	178
6.5	Madrid Trial	179
6.6	Malmo Trial	180
6.7	Terni Trial	180

List of tables

Table 1: Attributes of an (indicative) IndicativeClass type.....	13
Table 2: Attributes of an (indicative) ListClass type	13
Table 3: FINESCE trials live data licensing	14
Table 4: The attributes of the FINESCE API wrapping interface.....	15
Table 5: Attributes of a FINESCE API metadata object.....	15
Table 6: Attributes of the AuthRequest class.....	17
Table 7: Attributes of the AuthResponse class	17
Table 8: Attributes of the Buildings class	20
Table 9: Attributes of the Building class.....	20
Table 10: Attributes of the Address class.....	21
Table 11: Attributes of the MeasurementTypesReport class	23
Table 12: Attributes of the MeasurementType class	24
Table 13: Attributes of the MeasurementReport class.....	28
Table 14: Attributes of a Measurement class	28
Table 15: Attributes of a Value class	29
Table 16: Attributes of the BuildingModulesReport class	31
Table 17: Attributes of the BuildingZonesReport class	33
Table 18: Attributes of the BuildingZone class.....	33
Table 19: Attributes of the IssueResolutionPlanReport class	36
Table 20: Attributes of the IssueResolutionPlan class	37
Table 21: Attributes of the DemandResponseAction class	37
Table 22: Attributes of the IncentivePlanReport class.....	43
Table 23: Attributes of the IncentivePlan class.....	43
Table 24: Attributes of the IPAction class	44
Table 25: Attributes of the ContractReport class.....	49
Table 26: Attributes of the Contract class.....	49
Table 27: Attributes of the ContractAction class.	50
Table 28: Attributes of the EnergyCostsReport class.....	53
Table 29: Attributes of the EnergyCosts class.....	53
Table 30: Attributes of the TimeslotsReport class	55
Table 31: Attributes of the Timeslot class.....	55
Table 32: Attributes of the AlgoweightReport class	58
Table 33: Attributes of the Algoweight class	58
Table 34: Attributes of the RegionalEnergyReport class.....	61
Table 35: Attributes of the RegionalEnergy class.....	61
Table 36: Attributes of the VehiclesReport class	76
Table 37: Attributes of the Vehicle class.....	76
Table 38: Attributes of the ConnectionsReport class.	84
Table 39: Attributes of the Connection class.	84
Table 40: Attributes of the VehicleTypesReport class	86
Table 41: Attributes of the VehicleType class	87
Table 42: Attributes of the ChargingModesReport class	90
Table 43: Attributes of the ChargingMode class.....	90
Table 44: Attributes of the VehicleSupplyEquipmentReport class	93
Table 45: Attributes of the VehicleSupplyEquipment class	93
Table 46: Attributes of the ConnectionStatesReport class	100
Table 47: Attributes of the ConnectionState class.....	100

Table 48: Attributes of the SocialEventsReport class.....	108
Table 49: Attributes of the SocialEvent class	108
Table 50: Attributes of the Location class.....	109
Table 51: Attributes of the MetersReport class.....	112
Table 52: Attributes of the Meter class.....	112
Table 53: Attributes of the SectorsReport class.....	115
Table 54: Attributes of the Sector enumeration.....	115
Table 55: Attributes of the PriceReport class.....	119
Table 56: Attributes of the Price class.....	119
Table 57: Attributes of the PriceLocationReport class.....	126
Table 58: Attributes of the PriceLocation class.....	126
Table 59: Attributes of the PriceLocationDataReport class	128
Table 60: Attributes of the PriceLocationData class	128
Table 61: Attributes of the PriceLocationDataValueReport class.....	131
Table 62: Attributes of the PriceLocationDataValue class	131
Table 63: Attributes of the RegionsReport class.....	133
Table 64: Attributes of the Region class.....	133
Table 65: Attributes of the RegionalEnergyAvgReport class.....	138
Table 66: Attributes of the RegionalEnergyAvg class.....	138
Table 67: Attributes of the MachinesReport class	152
Table 68: Attributes of the MachineOverview class	152
Table 69: Attributes of the SingleMachineReport class.....	154
Table 70: Attributes of the MachineHistory class.....	154
Table 71: Attributes of the ComponentsReport class	157
Table 72: Attributes of the ComponentContainer class.....	158
Table 73: Attributes of the Component class.....	158
Table 74: Attributes of the ComponentDataReport class.....	160
Table 75: Attributes of the ComponentDataContainer class	160
Table 76: Attributes of the ComponentData class.....	160
Table 77: Attributes of TH WeatherAvailableOptions class.....	165
Table 78: Attributes of the WeatherDetails class	168

List of Figures

Figure 1: Class diagram of an (indicative)	13
Figure 2: Example of a service documentation section	13
Figure 3: The FINESCE API wrapping interface.....	15
Figure 4: Class diagram of an indicative RandomClass following the FINESCE API wrapping interface	15
Figure 5: Class diagram of the authentication request body	17
Figure 6: Class diagram of the authentication response body.....	17
Figure 7: Class diagram of the authentication refresh body.....	18
Figure 8: Class diagram of a report related to a list of Buildings request.....	20
Figure 9: Class diagram of a report related to a request for a list of MeasurementType objects.	23
Figure 10: Class diagram of a MeasurementReport response.....	28
Figure 11: Handling the measurement_type attribute of a Measurement object	29
Figure 12: Class diagram of a BuildingModulesReport response.....	31
Figure 13: Class diagram of a BuildingZonesReport response.	33
Figure 14: Class diagram of an IssueResolutionPlanReport response.	36
Figure 15: Class diagram of an IncentivePlanReport response	43
Figure 16: Class diagram of a ContractReport response.....	49
Figure 17: Class diagram of an EnergyCostsReport response	53
Figure 18: Class diagram of a TimeslotsReport response.	55
Figure 19: Class diagram of an AlgoweightReport response	58
Figure 20: Class diagram of a ChargingStatesReport response.....	59
Figure 21: Class diagram of a RegionalEnergyReport response.....	61
Figure 22: Class diagram of the VehiclesReport class	76
Figure 23: Class diagram of a ConnectionsReport response.....	84
Figure 24: Class diagram of the VehicleTypesReport class	86
Figure 25: Class diagram of a ChargingModesReport response	90
Figure 26: Class diagram of a VehicleSupplyEquipmentReport response.	92
Figure 27: Class diagram of a ConnectionStatesReport response.	100
Figure 28: Class diagram of the SocialEventsReport class.	108
Figure 29: Class diagram of a MetersReport response.	112
Figure 30: Class description of a SectorsReport response	115
Figure 31: Class diagram of a PriceReport response.....	119
Figure 32: Class diagram of a PriceLocationReport response	125
Figure 33: Class diagram of a PriceLocationDataReport response	128
Figure 34: Class diagram of a PriceLocationDataValueReport response.	131
Figure 35: Class diagram of a RegionsReport response.	133
Figure 36: Class diagram of a RegionalEnergyAvgReport response.....	137
Figure 37: Class diagram of a PredictionReport response	146
Figure 38: Class diagram of a MachinesReport response.	152
Figure 39: Class diagram of a SingleMachineReport response.	154
Figure 40: Class diagram of a SingleMachineReport response (full depth analysis).....	155
Figure 41: Class diagram of a ComponentsReport response	157
Figure 42: Class diagram of a ComponentDataReport.....	160
Figure 43: Class diagram of a WeatherAvailableOptions response.	165
Figure 44: Class diagram of a WeatherDetails response.....	167

1 Preface

1.1 About this document

This document details the application programming interfaces (APIs) as specified by the global FINESCE API. For information about the FINESCE project, the interested reader is requested to visit the official FINESCE API website [1].

1.2 Who should read this document

This document is meant to be ready by anyone interested to use or adopt the FINESCE API specification in order to interact with or offer FINESCE API-compatible services.

1.3 How should this document be read

Section 2 provides all the information needed to the interested readers. The structure of the document follows a strict structure to enhance API readability. In this context, sections 2.X (X = 1, ..., 16) denote the start of a new group of APIs, namely all services documented under such a section share the same general service scope. The different services exposed by each group of APIs have been marked as sections following the numbering format 2.X.Y, where Y indicates the index of the service in the API group in hand. Last, sections numbered as 2.X.Y.Z offer indicative requests and responses when triggering service 2.X.Y.

The documentation lying in the sections numbered in the 2.X.Y format (indicating service Y of the API group X) also follows a common format throughout the whole document. Specifically, following the service title, the endpoint URL of the specific service is documented which, in turn, is also followed by a brief description of the service functionality. Next, the (path or query) parameters of the service are tabulated, explicitly stating the name of the parameter, its type and description. In addition to this information, an indicative value for each parameter is provided.

Having defined the structure of the Endpoint URL, the service description is continued with a UML Class diagram providing an overview of the connection on data-model basis of the various object classes involved in the request/response to/from the service. The UML Class diagram is also accompanied by a number of tables documenting the various fields that compose the request/response classes of interest.

Regarding the sections numbered as 2.X.Y.Z containing exemplary use of the service, including the request/response bodies (if any) along with the HTTP headers used for the request (if needed). In case the service endpoint URL needs to be configured with a set of parameters, the example provided is using the indicative parameter values appearing in the table documenting the service (path or query) parameters.

An indicative Service API documentation section is presented below. This indicative service may be invoked through the endpoint URL `/{version}/{trial}/service/{parameter}`. Since the words in the curly brackets indicate endpoint URL parameters, this endpoint URL can be configured by three parameters, namely API version, trial hosting the service and, last, the service parameter called 'parameter'. The class type of the response is of IndicativeClass type, the respective class diagram being depicted in Figure 1.

The document also reflects the current state of implementation of the FINESCE API Mediator (FAM) DSE [2], the latter being the actual software infrastructure implementing the FINESCE API specification and interconnecting the various FINESCE trials. Optimally, the current documentation should be combined with a critical examination of the two FINESCE API Mediator DSE documentation and experimentation services hosted in the DSE's default Swagger [3] interface [4] and Apiary [5].

6.X.Y Specific Service Title

Endpoint URL: [/{version}/{trial}/service/{parameter}]

Brief service functionality description.

Parameters

Name	Type	Example	Description
version	String	v0.1	The version of the API to use
trial	String	Horsens	The trial infrastructure to use when invoking the respective service
parameter	Parameter Type	indicative parameter value	Parameter description

The class type of the response (instance of Indicative class) is depicted in Figure 1, below.

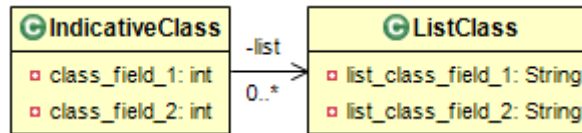

Figure 1: Class diagram of an (indicative)

Table 1: Attributes of an (indicative) IndicativeClass type

Name	Type	Description
class_field_1	Integer	Class field description
class_field_2	Integer	Class field description
list	List<ListClass>	A list of ListClass objects (documented in the next table)

Table 2: Attributes of an (indicative) ListClass type

Name	Type	Description
list_class_field_1	String	Class field description
list_class_field_2	String	Class field description

6.X.Y.1 Retrieve a list of IndicativeClass objects [GET]

Request

- Headers
 1. x-auth-token: `an_auth_token`
 2. Accept: `application/json`

Response 200 (application/json)

- Body
 3. {
 4. . . .
 5. }

Figure 2: Example of a service documentation section

1.4 Legal Notice

As the FINESCE trials are tightly bound to real infrastructure uses and interface with actual end-users (customers), the use of the data originating from the FINESCE platform is subject to trial-specific treatment. In this context, the following table summarizes the approach of the various FINESCE trials with respect to data licensing.

Table 3: FINESCE trials live data licensing

Trial	Requires NDA	Data Handling
Malmo	No	Data are open for public use ¹
Horsens	Yes	An NDA with the trial owner should be signed
Madrid	No	Data are open for public use
Virtual Power Plant	No	Data are open for public use
Smart Factory	No	Data are open for public use
Terni	Yes	An NDA with the trial owner should be signed
Ireland	Yes	An NDA with the trial owner should be signed

For all trials offering open data, the CC-by-SA license [6] is used, allowing for “*re-distribution and re-use of a licensed work on the conditions that the creator is appropriately credited and that any derivative work is made available under “the same, similar or a compatible license”*”. Data originating from the trials requiring NDA will be available under the terms specified in the NDA, which are available from the respective trial site owner.

1.5 FINESCE data availability and further exploitation

The FINESCE API Mediator DSE is envisioned to be mediating trial data after the end of the project (September 2015) without any foreseen time restriction. However, the period during which the FINESCE trials will continue to offer live data after the end of the project varies per trial.

A historical, anonymised version of the gathered FINESCE data will be made available after the end of the FINESCE project as Open Data under a CC-by-SA license. This offering is currently under development and further information on it will be published on the FINESCE web site.

¹ Weather data originate from the online web service <http://www.yr.no/> and not from the trial infrastructure.

2 FINESCE API Specification

FINESCE API follows a common convention with regards to responses, using a standard, lightweight envelop to wrap the FINESCE-API compatible responses. Specifically, this standard wrapper includes a Metadata object documented in Table 4 and Table 5 and is depicted as a UML Class diagram in

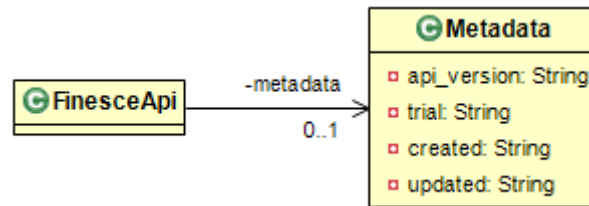

Figure 3: The FINESCE API wrapping interface

Table 4: The attributes of the FINESCE API wrapping interface

Name	Type	Description
metadata	Metadata	The metadata of the report (see Table 5, page 15)

Table 5: Attributes of a FINESCE API metadata object

Name	Type	Description
api_version	String	The version of the API specification used
trial	String	The name of the responder trial site
created	String	The time when the report was created (in ISO8601 CET)
updated	String	The time when the report was updated (in ISO8601 CET)

Every class implemented as a response of a FINESCE API resource inherits this standard interface, so the FINESCE API classes are always implemented and documented as class diagrams as follows:

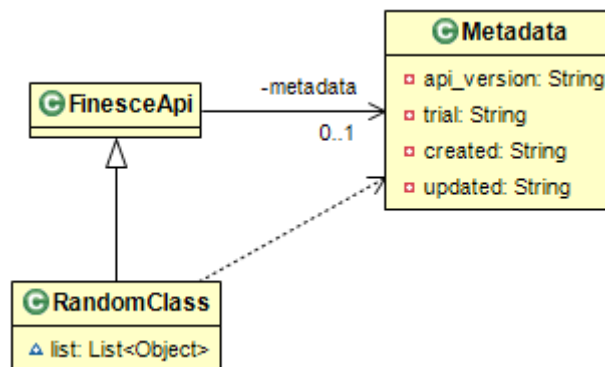

Figure 4: Class diagram of an indicative RandomClass following the FINESCE API wrapping interface

The JSON representation of the RandomClass encapsulation into the FINESCE API, is as follows:

```

6. {
7.   "metadata":{
8.     "api_version":"0.1",
9.     "trial":"A_Trial",
10.    "created":"ISO8601 date",
11.    "updated":" ISO8601 date"
12.  },

```

```
13.  list:[  
14.  
15.  ]  
16. }
```

Having in mind the above discussion, in the next paragraphs the FINESCE API is documented.

2.1 Authentication

This set of APIs is used for authenticating users against oauth2 authentication and authorization services.

2.1.1 Authenticate a user

Endpoint URL: [/{version}/{trial}/tokens]

Authenticates a user against a set of credentials. 'Horsens', 'Malmo', 'Aachen' (VPP services), Terni and 'Ireland' are the trials offering this service.

Parameters

Name	Type	Example	Description
version	String	v0.1	The version of the API to use.
trial	String	Ireland	The trial infrastructure to use for invoking the respective service.

Since only a POST request is foreseen from the service, a relevant body request should be defined. Next, the class diagram of the request object is presented, followed by the class diagram of the response, in Figure 6.

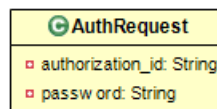

Figure 5: Class diagram of the authentication request body

Table 6: Attributes of the AuthRequest class

Name	Type	Description
authorization_id	String	The id of the user initiating the authentication process, e.g. the email of the user
password	String	The secret (password) of the user

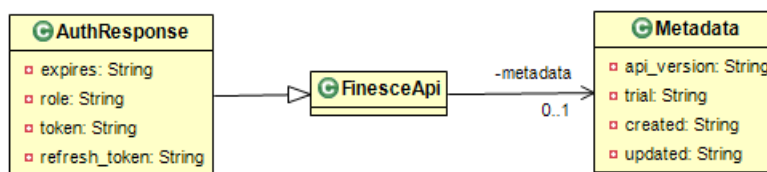

Figure 6: Class diagram of the authentication response body

Table 7: Attributes of the AuthResponse class

Name	Type	Description
metadata	Metadata	The metadata of the report (see Table 5, page 15)
expires	String	The time of the token expiration
role	String	The role of the user
token	String	The actual token to be used
refresh_token	String	A refresh token

Note that the response (AuthResponse class in the diagram) follows the standard FINESCE API response wrapping presentation, as presented in paragraph 1.3, page 12.

2.1.1.1 Get an authorization token based on user data [POST]

Request

- Headers
 1. Accept: `application/json`
 2. Content-Type: `application/json`
- Body
 1. {
 2. `"authorization_id": "an_auth_id",`
 3. `"password": "a_password"`
 4. }

Response 200 (application/json)

- Body
 1. {
 2. `"metadata":{`
 3. `"api_version": "0.1",`
 4. `"trial": "Ireland",`
 5. `"created": "2015-01-20T16:49:30+02:00",`
 6. `"updated": "2015-01-20T16:49:30+02:00"`
 7. `},`
 8. `"expires": "2015-01-20T16:49:30+02:00",`
 9. `"role": "a_role",`
 10. `"token": "an_auth_token",`
 11. `"refresh_token": "a_refresh_token"`
 12. }

2.1.2 Refresh a token

Endpoint URL: `[/version]/{trial}/tokens/refresh`

Retrieves a new authentication token based on a previously issued refresh token. 'Horsens' and 'Ireland' are the trials offering this service.

Parameters

Name	Type	Example	Description
<i>version</i>	String	v0.1	The version of the API to use.
<i>trial</i>	String	Ireland	The trial infrastructure to use for invoking the respective service.

Similarly to the `[/version]/{trial}/tokens` (2.1.1) service, only a POST request is foreseen from the service, so a relevant body request should be defined. Next, the class diagram of the request object is presented.

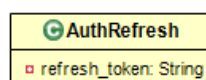

Figure 7: Class diagram of the authentication refresh body

Name	Type	Description
<code>refresh_token</code>	String	The refresh token to validate the request

The class diagram of the service response is the same as presented in 2.1.1 and is, thus, omitted.

2.1.2.1 Get a refreshed authentication token [POST]

Request

- Headers
 1. Accept: `application/json`
 2. Content-Type: `application/json`
- Body
 1. {
 2. `"refresh_token": "a_refresh_token"`
 3. }

Response 200 (application/json)

- Body
 1. {
 2. `"metadata":{`
 3. `"api_version": "0.1",`
 4. `"trial": "Ireland",`
 5. `"created": "2015-01-20T16:51:25+02:00",`
 6. `"updated": "2015-01-20T16:51:25+02:00"`
 7. `},`
 8. `"expires": "2015-01-20T16:51:25+02:00",`
 9. `"role": "a_role",`
 10. `"token": "an_auth_token",`
 11. `"refresh_token": "a_refresh_token"`
 12. }

2.2 Building information

This set of APIs provide access to information related to smart buildings presentation.

2.2.1 Get list of buildings in trial

Endpoint URL: [/{version}/{trial}/buildings]

List the buildings known to the selected trial infrastructure. 'Horsens' is the only trial offering this service.

Parameters

Name	Type	Example	Description
version	String	v0.1	The version of the API to use.
trial	String	Horsens	The trial infrastructure to use for invoking the respective service.

The class diagram of the reponse (instance of Buildings) of the service follows in Figure 8.

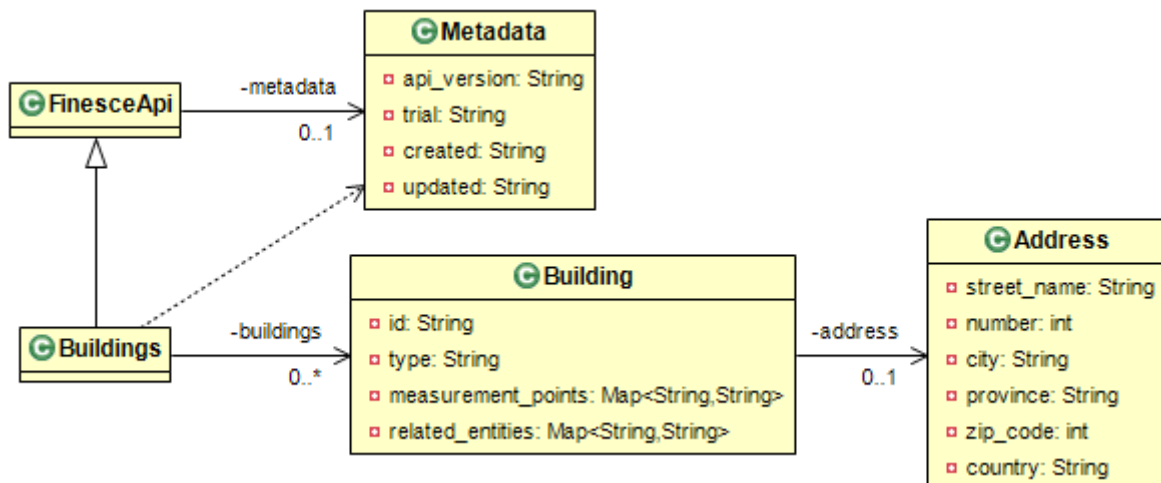

Figure 8: Class diagram of a report related to a list of Buildings request

Table 8: Attributes of the Buildings class

Name	Type	Description
metadata	Metadata	The metadata of the report (see Table 5, page 15)
buildings	List<Building>	The list of trial buildings of interest (see Table 9, page 20)

Table 9: Attributes of the Building class

Name	Type	Description
id	String	The id of the building
type	String	The type of the building
measurement_points	Map<String,String>	The types of measurements that are associated with the specific building
related_entities_ids	Map<String,String>	A list of entities associated with the building in hand (e.g. a vehicle)
address	Address	The address of the building (see Table 10, page 21)

Table 10: Attributes of the Address class

Name	Type	Description
street_name	String	The street name of the building address
number	Integer	The number of the building address
city	String	The city of the building address
province	String	The province of the building address
zip	Integer	The zip code of the building address
country	String	The country of the building address

2.2.1.1 Retrieve a list of building descriptions [GET]

Request

- Headers
 1. x-auth-token: `an_auth_token`
 2. Accept: `application/json`

Response 200 (application/json)

- Body
 1. {
 2. "metadata":{
 3. "api_version":"0.1",
 4. "trial":"Ireland",
 5. "created":"2015-03-06T11:44:39+02:00",
 6. "updated":"2015-03-06T11:44:39+02:00"
 7. },
 8. "buildings":[
 9. {
 10. "id":"1234",
 11. "type":"House",
 12. "address":{
 13. "street_name":"A street name",
 14. "number":1,
 15. "city":"A city",
 16. "province":"A provice",
 17. "zip_code":12345,
 18. "country":"A Country"
 19. },
 20. "measurement_points":{
 21. "hmhf-1234":"HeatpumpHeatFlow",
 22. "ita-1234":"IndoorTemperatureAverage"
 23. },
 24. "related_entities":{
 25. "Vehicle#1234":"Vehicle"
 26. }
 27. },
 28. {
 29. "id":"4567",
 30. "type":"House",
 31. "address":{
 32. "street_name":"A street name",
 33. "number":1,
 34. "city":"A city",
 35. "province":"A provice",
 36. "zip_code":12345,
 37. "country":"A Country"

```

38.         },
39.         "measurement_points":{
40.             "ita-4567":"IndoorTemperatureAverage",
41.             "hmf-4567":"HeatpumpHeatFlow"
42.         },
43.         "related_entities":{
44.             "Vehicle#4567":"Vehicle"
45.         }
46.     }
47. ]
48. }

```

2.2.2 Get building Description

Endpoint URL: `[/{version}/{trial}/buildings/{id}]`

List the properties of the identified building. The measurement types associated with the building are delivered as well. 'Horsens' is the only trial offering this service.

Parameters

Name	Type	Example	Description
<i>version</i>	String	v0.1	The version of the API to use.
<i>trial</i>	String	Horsens	The trial infrastructure to use for invoking the respective service.
<i>id</i>	String	1234	The id of the building to be displayed.

The data model of the answer is the same as the one documented in paragraph 2.2.1.

2.2.2.1 Retrieve a description of a single building [GET]

Request

- Headers
 1. x-auth-token: `an_auth_token`
 2. Accept: `application/json`

Response 200 (application/json)

- Body
 1. {
 2. "metadata":{
 3. "api_version":"0.1",
 4. "trial":"Horsens",
 5. "created":"2015-02-26T13:53:10+02:00",
 6. "updated":"2015-02-26T13:53:10+02:00"
 7. },
 8. "buildings":[
 9. {
 10. "id":"1234",
 11. "type":"House",
 12. "address":{
 13. "street_name":"A street name",
 14. "number":1,
 15. "city":"A city",

```

16.         "province": "A province",
17.         "zip_code": 12345,
18.         "country": "A Country"
19.     },
20.     "measurement_points": {
21.         "hmf-1234": "HeatpumpHeatFlow",
22.         "ita-1234": "IndoorTemperatureAverage"
23.     },
24.     "related_entities": {
25.         "Vehicle#1234": "Vehicle"
26.     }
27. }
28. ]
29. }
    
```

2.2.3 Get available measurement types for a specific building

Endpoint URL: `/{version}/{trial}/buildings/{id}/measurement_types`

Provides information regarding the available measurements types for the specific building. A valid {id} can be obtained by the `/{version}/{trial}/buildings` service. 'Horsens' is the only trial offering this service.

Parameters

Name	Type	Example	Description
<i>version</i>	String	v0.1	The version of the API to use.
<i>trial</i>	String	Horsens	The trial infrastructure to use for invoking the respective service.
<i>id</i>	String	1234	The id of the building to query for measurement types.

The class diagram of the response (instance of a MeasurementTypesReport class) is presented in Figure 9.

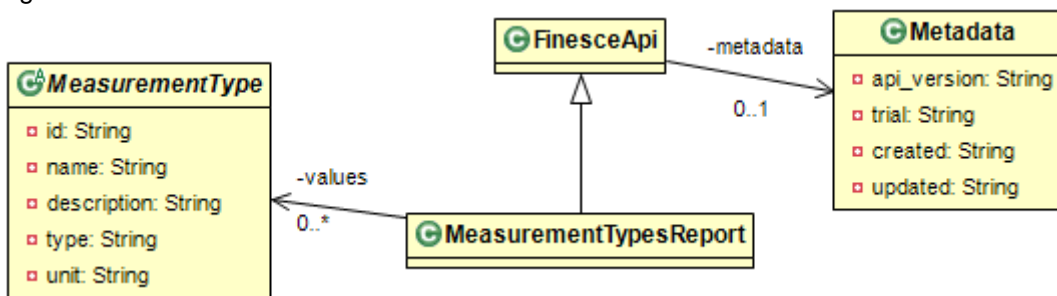

Figure 9: Class diagram of a report related to a request for a list of MeasurementType objects.

Table 11: Attributes of the MeasurementTypesReport class

Name	Type	Description
metadata	Metadata	The metadata of the report (see Table 5, page 15)
value	List<MeasurementType>	The list of measurement types of interest (see Table Table 12, page 24)

Table 12: Attributes of the MeasurementType class

Name	Type	Description
id	String	The id of the measurement type
name	String	The descriptive name of the measurement type
description	String	The description of the measurement type
type	String	The type of the measurement
unit	String	The unit of the measurement

2.2.3.1 Retrieve the list of available measurement types for a building [GET]

Request

- Headers
 1. x-auth-token: `an_auth_token`
 2. Accept: `application/json`

Response 200 (application/json)

- Body
 1. {
 2. "metadata":{
 3. "api_version":"0.1",
 4. "trial":"Horsens",
 5. "created":"2014-12-30T19:52:13+02:00",
 6. "updated":"2014-12-30T19:52:13+02:00"
 7. },
 8. "measurement_types":[
 9. {
 10. "id":null,
 11. "name":"IndoorTemperatureAverage",
 12. "description":"Indoor temperature average for period",
 13. "type":"Temperature",
 14. "unit":"C"
 15. }
 16.]
 17. }

2.2.4 Get the available measurement types for the trial

Endpoint URL: `[/{version}]/{trial}/buildings/measurement_types]`

Provides a detailed list of all the available building measurements types in the trial. 'Horsens' is the only trial offering this service.

Parameters

Name	Type	Example	Description
<i>version</i>	String	v0.1	The version of the API to use.
<i>trial</i>	String	Horsens	The trial infrastructure to use for invoking the respective service.

The class diagram of the response (instance of a MeasurementTypesReport class) is presented in Figure 9, page 23. The detailed description of the response attributes is given in Table 11, page 23.

2.2.4.1 Retrieve the list of available measurement types [GET]

Request

- Headers
 1. x-auth-token: `an_auth_token`

Response 200 (application/json)

- Body
 1. {
 2. "metadata":{
 3. "api_version":"0.1",
 4. "trial":"Horsens",
 5. "created":"2014-12-30T20:00:39+02:00",
 6. "updated":"2014-12-30T20:00:39+02:00"
 7. },
 8. "measurement_types":[
 9. {
 10. "id":null,
 11. "name":"IndoorTemperatureAverage",
 12. "description":"Indoor temperature average for period",
 13. "type":"Temperature",
 14. "unit":"C"
 15. },
 16. {
 17. "id":null,
 18. "name":"HouseNaturalGasConsumption",
 19. "description":"Accumulated house natural gas consumption f
 20. "or all time",
 21. "type":"Volume",
 22. "unit":"m^3"
 23. },
 24. {
 25. "id":null,
 26. "name":"ICMIndoorCO2LevelAverage",
 27. "description":"Indoor CO2 level average as measured by IC-
 28. "Meter",
 29. "type":"-",
 30. "unit":"ppm"
 31. }
 32.]
 33. }

2.2.5 Get the available measurement types for the trial, based on their id

Endpoint URL: `/{version}/{trial}/buildings/measurement_types/id/{id}`

Provides a detailed list of all the available measurements types that match a specific measurements type name. A valid {id} can be obtained by calling the `/{version}/{trial}/buildings/measurement_types` service. 'Horsens' is the only trial offering this service.

Parameters

Name	Type	Example	Description
<i>version</i>	String	v0.1	The version of the API to use.
<i>trial</i>	String	Horsens	The trial infrastructure to use for invoking the respective service.
<i>id</i>	String	IndoorTemperatureAverage	The id of the measurement type to query for.

The class diagram of the response (instance of a MeasurementTypesReport class) is presented in Figure 9, page 23. The detailed description of the response attributes is given in Table 11, page 23.

2.2.5.1 Retrieve a list of measurement types, based on their id [GET]

Request

- Headers
 1. x-auth-token: `an_auth_token`
 2. Accept: `application/json`

Response 200 (application/json)

- Body
 1. {
 2. "metadata":{
 3. "api_version":"0.1",
 4. "trial":"Horsens",
 5. "created":"2014-12-30T20:02:41+02:00",
 6. "updated":"2014-12-30T20:02:41+02:00"
 7. },
 8. "measurement_types":[
 9. {
 10. "id":null,
 11. "name":"IndoorTemperatureAverage",
 12. "description":"Indoor temperature average for period",
 13. "type":"Temperature",
 14. "unit":"C"
 15. }
 16.]
 17. }

2.2.6 Get the available measurement types for buildings, based on their type

Endpoint URL: `/{version}/{trial}/buildings/measurement_types/type/{type}`

Provides a detailed list of all the available measurements types that match a specific measurements type. A valid {type} can be obtained by calling the `/{version}/{trial}/buildings/measurement_types` service and check the 'type' attribute of the answer. 'Horsens' is the only trial offering this service.

Parameters

Name	Type	Example	Description
<i>version</i>	String	v0.1	The version of the API to use.

<i>trial</i>	String	Horsens	The trial infrastructure to use for invoking the respective service.
<i>type</i>	String	temperature	The type of the measurement type to query for.

The class diagram of the response (instance of a MeasurementTypesReport class) is presented in Figure 9, page 23. The detailed description of the response attributes is given in Table 11, page 23.

2.2.6.1 Retrieve a list of measurement types, based on their type [GET]

Request

- Headers
 1. x-auth-token: `an_auth_token`
 2. Accept: `application/json`

Response 200 (application/json)

- Body
 1. {
 2. "metadata":{
 3. "api_version":"0.1",
 4. "trial":"Horsens",
 5. "created":"2014-12-30T20:05:44+02:00",
 6. "updated":"2014-12-30T20:05:44+02:00"
 7. },
 8. "measurement_types":[
 9. {
 10. "id":null,
 11. "name":"IndoorTemperatureAverage",
 12. "description":"Indoor temperature average for period",
 13. "type":"Temperature",
 14. "unit":"C"
 15. }
 16.]
 17. }

2.2.7 Get the available measurements for a specific building

Endpoint URL: `[/{version}]/{trial}/buildings/{id}/measurements/{type_id}/{from}/{to}`

Provides information regarding the available measurements of a specific type for a specific building, during a certain period of time. A valid {id} can be obtained by calling the /buildings service. A valid {type_id} can be obtained by calling the /buildings service and check the 'measurement_points' section of the answer. Valid {from} and {to} values are expressed in ISO8601 format. 'Horsens' is the only trial offering this service.

Parameters

Name	Type	Example	Description
<i>version</i>	String	v0.1	The version of the API to use.
<i>trial</i>	String	Horsens	The trial infrastructure to use for invoking the respective service.

<i>id</i>	String	1234	The id of the building to query for measurement types.
<i>type_id</i>	String	IndoorTemperatureAverage	The id of the measurement type to query the building for.
<i>from</i>	String	2014-12-29T19:52:13+02:00	The lower limit of the duration of the query, in an ISO8601 compatible format
<i>to</i>	String	2014-12-29T20:52:13+02:00	The upper limit of the duration of the query, in an ISO8601 compatible format

The class diagram of the response (instance of a MeasurementReport class) is presented in Figure 10.

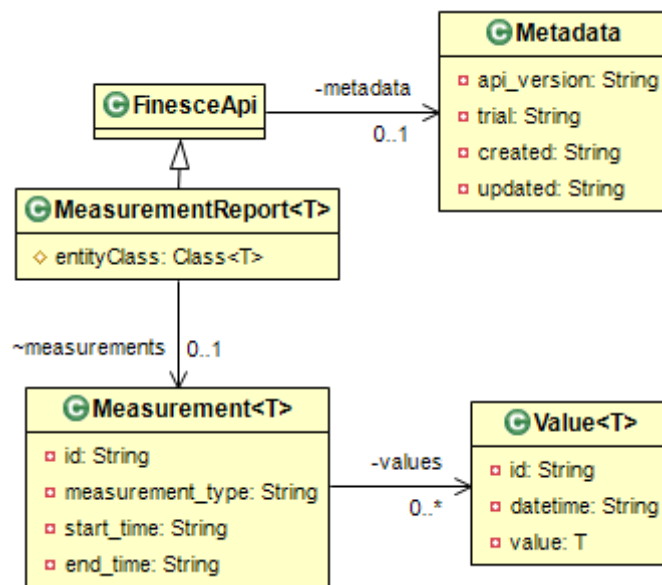

Figure 10: Class diagram of a MeasurementReport response.

As can be deduced from Figure 10, the MeasurementReport instance acts as a FINESCE API wrapper for a Measurement object which, in turn, acts as a container for a number of measured values. The details of the MeasurementReport and Measurement classes are given in Table 13 - Table 15.

Table 13: Attributes of the MeasurementReport class

Name	Type	Description
metadata	Metadata	The metadata of the report (see Table 5, page 15)
measurements	T extends Measurement	The measurement report per se (see Table 14, page 28)

Table 14: Attributes of a Measurement class

Name	Type	Description
id	String	The id of the measurements container
measurement_type	String	The type of the measurement
start_time	String	The start time of the report, in an ISO8601

start_time	String	compatible format The end time of the report, in an ISO8601 compatible format
values	List<Value<T>>	The list of values accompanying the measurement (see Table 15, page 29). T is the class type of the measured values (e.g. double, int, String)

Table 15: Attributes of a Value class

Name	Type	Description
id	String	The id of the specific measurement
datetime	String	The date/time of the measurement, expressed in ISO8601 format
value	T	The value of the measurement. T is the class type of the measured value (e.g. double, int, String)

Based on its specification, a Measurement object is dependent on the actual measured values that it is encapsulating. From a technical perspective, it is possible to specify the measurement_type attribute of the object both explicitly (passing the measurement type as a string) and explicitly (passing the measurement type as a MeasurementType instance – see Table 12, page 24 for details) and setting the Measurement's measurement_type attribute equal to the name of the MeasurementType object. Figure 11 depicts the two alternative implementations.

```

public Measurement(String identifier, String type) {
    this.id = identifier;
    this.measurement_type = type;
    this.values = new ArrayList<>();
}

public Measurement(String identifier, MeasurementType type) {
    this.id = identifier;
    this.measurement_type = type.getName();
    this.values = new ArrayList<>();
}

```

Figure 11: Handling the measurement_type attribute of a Measurement object

Based on the input gathered from the various FINESCE trials, a number of measurement type names have been compiled and are as follows:

BatteryCapacity, BatteryLevel, ChargingSocketPowerConsumption, ChargingSocketPowerDemand, CloudCover, ColdWaterTemperatureAverage, Distance, EnergyConsumption, EnergyConsumptionGrid, EnergyProduction, EnergyProductionGrid, EnergyProductionSolar, EnergyStatus, EnergyStatusSingleton, GlobalHorizontalIrradiance, HeatConsumption, HeatEnergyAverage, HeatpumpForwardFlowTemperatureAverage, HeatpumpHeatFlow, HeatpumpInletFlowDemand, HeatpumpInletFlowSummation, HeatpumpInletTemperature, HeatpumpOutletFlowDemand, HeatpumpOutletFlowSummation, HeatpumpOutletTemperature, HeatpumpPowerAverage, HeatpumpReturnFlowTemperatureAverage, HotWaterEnergyAverage, HotWaterFlow, HotWaterTemperatureAverage, ICMIIndoorCO2LevelAverage, ICMIIndoorHumidityAverage, ICMIIndoorTemperatureAverage, Illuminance, IndoorTemperatureAverage, MaxTemperature, MinTemperature, ModuleStatus, NaturalGasConsumption, OutdoorTemperatureAverage, Position, PowerDemand, PowerDemandGrid, PowerMixed, PowerSupply, PowerSupplyGrid,

RelativeHumidity, Speed, SunriseTime, SunsetTime, Temperature, WindDirection and WindSpeed.

Note that not all measurement types are available to all trials.

2.2.7.1 Retrieve the list of available measurements for a building [GET]

Request

- Headers
 1. x-auth-token: `an_auth_token`
 2. Accept: `application/json`

Response 200 (application/json)

- Body
 1. {
 2. "metadata":{
 3. "api_version":"0.1",
 4. "trial":"Horsens",
 5. "created":"2015-01-12T15:35:26+01:00",
 6. "updated":"2015-01-12T15:35:26+01:00"
 7. },
 8. "measurements":{
 9. "measurement_type":"IndoorTemperatureAverage",
 10. "values":[
 11. {
 12. "id":null,
 13. "datetime":"2015-01-12T15:35:26+01:00",
 14. "value":18
 15. },
 16. {
 17. "id":null,
 18. "datetime":"2015-01-12T15:35:26+01:00",
 19. "value":19
 20. }
 21.],
 22. "start_time":null,
 23. "end_time":null
 24. }
 25. }

2.2.8 Get the available building components/modules

Endpoint URL: `[/{version}]/{trial}/buildings/{id}/modules]`

Provides a list of devices or modules which status can be monitored by the Building Control Centre. 'Madrid' is the only trial offering this service.

Parameters

Name	Type	Example	Description
<i>version</i>	String	v0.1	The version of the API to use.
<i>trial</i>	String	Madrid	The trial infrastructure to use for invoking the respective service.
<i>id</i>	String	1	The id of the building of interest

The class diagram of the response (instance of a BuildingModulesReport class) is presented in Figure 12.

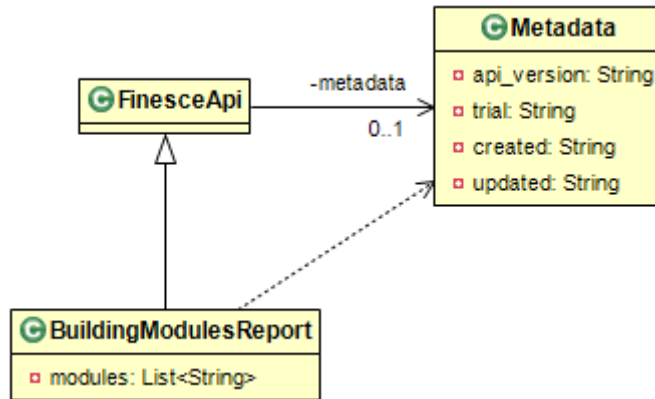

Figure 12: Class diagram of a BuildingModulesReport response.

The attributes of the relevant service response class are documented in the table following.

Table 16: Attributes of the BuildingModulesReport class

Name	Type	Description
metadata	Metadata	The metadata of the report (see Table 5, page 15)
modules	List<String>	The list of module names

2.2.8.1 Retrieve the available building components/modules [GET]

Request

- Headers
 1. Accept: `application/json`

Response 200 (application/json)

- Body
 1. {
 2. "metadata":{
 3. "api_version":"0.1",
 4. "trial":"Madrid",
 5. "created":"2015-02-26T16:57:27+02:00",
 6. "updated":"2015-02-26T16:57:27+02:00"
 7. },
 8. "modules":[
 9. "boiler",
 10. "fancoil",
 11. "cooler",
 12. "atu"
 13.]
 14. }

2.2.9 Get the status of a building component/module

Endpoint URL: `[/version]/{trial}/buildings/{id}/modules/{module_id}/status/{date}`

Provides information about the status of a specific building module. The available building modules may be retrieved via the `/version/{trial}/buildings/{id}/modules` service. Valid `{date}` values are expressed in ISO8601 format. 'Madrid' is the only trial offering this service.

Parameters

Name	Type	Example	Description
<i>version</i>	String	v0.1	The version of the API to use.
<i>trial</i>	String	Madrid	The trial infrastructure to use for invoking the respective service.
<i>id</i>	String	1	The id of the building of interest
<i>module_id</i>	String	boiler	The module of interest
<i>date</i>	String	2015-02-28T00:00:00+02:00	The date to fetch information for, in ISO8601 compliant format

The class diagram of the response (instance of MeasurementReport) has already been presented in Figure 10, page 28, using “Status” as the measurement type.

2.2.9.1 Get the status of a building component/module [GET]**Request**

- Headers
 1. Accept: `application/json`

Response 200 (application/json)

- Body
 1. {
 2. "metadata":{
 3. "api_version":"0.1",
 4. "trial":"Madrid",
 5. "created":"2015-02-26T16:12:42+01:00",
 6. "updated":"2015-02-26T16:12:42+01:00"
 7. },
 8. "measurements":{
 9. "measurement_type":"Status",
 10. "values":[
 11. {
 12. "id":null,
 13. "datetime":"2015-02-28T00:00:00+02:00",
 14. "value":1
 15. }
 16.],
 17. "start_time":null,
 18. "end_time":null
 19. }
 20. }

2.2.10 Get the available building zones

Endpoint URL: `/{version}/{trial}/buildings/{id}/zones]`

Provides a list of zones of a building. 'Madrid' is the only trial offering this service.

Parameters

Name	Type	Example	Description
version	String	v0.1	The version of the API to use.
trial	String	Madrid	The trial infrastructure to use for invoking the respective service.
id	String	1	The id of the building of interest

The class diagram of the response (instance of a BuildingZonesReport class) is presented in Figure 13.

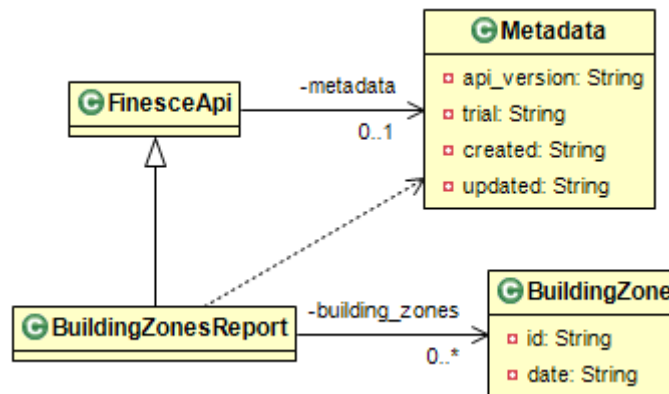

Figure 13: Class diagram of a BuildingZonesReport response.

The attributes of the relevant service response class are documented in the table followings.

Table 17: Attributes of the BuildingZonesReport class

Name	Type	Description
metadata	Metadata	The metadata of the report (see Table 5, page 15)
building_zones	List<BuildingZone>	The list of building zones

Table 18: Attributes of the BuildingZone class

Name	Type	Description
id	String	The id of the building zone
date	String	The last date the building zone was reported active in an ISO8601 compliant format

2.2.10.1 Retrieve the available building zones [GET]

Request

- Headers
 1. Accept: `application/json`

Response 200 (application/json)

- Body
 1. {
 2. "metadata":{
 3. "api_version":"0.1",

```

4.     "trial": "Madrid",
5.     "created": "2015-02-26T17:12:20+02:00",
6.     "updated": "2015-02-26T17:12:20+02:00"
7.   },
8.   "building_zones": [
9.     {
10.      "id": "bz1",
11.      "date": "2015-02-28T00:00:00+02:00"
12.    },
13.    {
14.      "id": "bz2",
15.      "date": "2015-02-28T00:00:00+02:00"
16.    },
17.    {
18.      "id": "bz3",
19.      "date": "2015-02-28T00:00:00+02:00"
20.    }
21.  ]
22. }

```

2.2.11 Get the available measurements of a building zone

Endpoint URL: `/{version}/{trial}/buildings/{id}/zone/{zone_id}/{measurement_type}/{date}`

Provides measurements of a certain type of a building zone. Valid measurement types are PowerDemandGrid, EnergyConsumptionGrid, Temperature, RelativeHumidity and BatteryLevel. The available building zones may be retrieved via the `/{version}/{trial}/buildings/{id}/zones` service. Valid `{date}` values are expressed in ISO8601 format. 'Madrid' is the only trial offering this service.

Parameters

Name	Type	Example	Description
<i>version</i>	String	v0.1	The version of the API to use.
<i>trial</i>	String	Madrid	The trial infrastructure to use for invoking the respective service.
<i>id</i>	String	1	The id of the building of interest
<i>zone_id</i>	String	bz1	The zone of interest
<i>measurement_type</i>	String	RelativeHumidity	The type of the measurements
<i>date</i>	String	2015-02-28T00:00:00+02:00	The date to fetch information for, in ISO8601 compliant format

The class diagram of the response (instance of MeasurementReport) has already been presented in Figure 10, page 28, using "RelativeHumidity" as the measurement type.

2.2.11.1 Get the status of a building component/module [GET]

Request

- Headers
 1. Accept: `application/json`

Response 200 (application/json)

• Body

```
1. {
2.   "metadata":{
3.     "api_version":"0.1",
4.     "trial":"Madrid",
5.     "created":"2015-02-26T17:16:32+02:00",
6.     "updated":"2015-02-26T17:16:32+02:00"
7.   },
8.   "measurements":{
9.     "measurement_type":"RelativeHumidity",
10.    "values":[
11.      {
12.        "id":null,
13.        "datetime":"2015-02-28T00:00:00+02:00",
14.        "value":56
15.      }
16.    ],
17.    "start_time":null,
18.    "end_time":null
19.  }
20. }
```

2.3 Demand Response

This group of APIs offers services related to demand/response and incentive plans, also exposing services related to contractual energy prices.

2.3.1 Get the list of issue resolution plans sharing a common author

Endpoint URL: `[/{version}/{trial}/dsm/irp/author/{author}]`

Allows a user to get a list of issue resolution plans based on their author name. 'Terni' is the only trial offering this service.

Parameters

Name	Type	Example	Description
<i>version</i>	String	v0.1	The version of the API to use.
<i>trial</i>	String	Terni	The trial infrastructure to use for invoking the respective service.
<i>author</i>	String	finesce-wp4-aggregator	The author (aggregator) of the issue resolution plans.

The class diagram of the response (instance of an IssueResolutionPlanReport class) is presented in

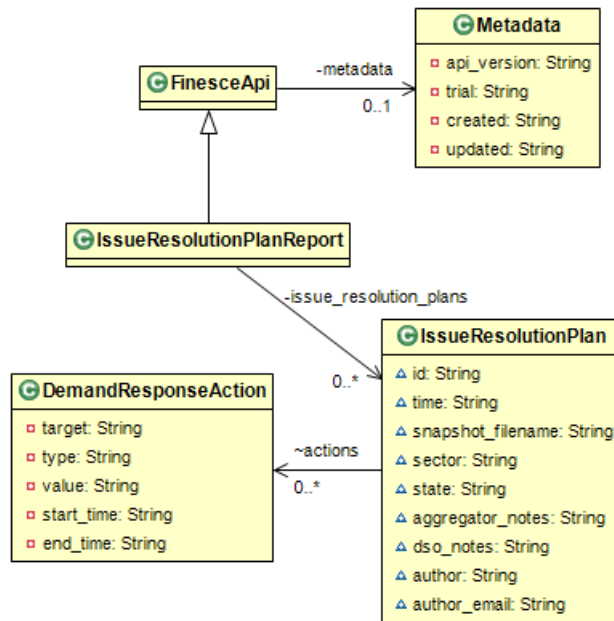

Figure 14: Class diagram of an IssueResolutionPlanReport response.

The definitions of the attributes composing the relevant classes follow.

Table 19: Attributes of the IssueResolutionPlanReport class

Name	Type	Description
metadata	Metadata	The metadata of the report (see Table 5, page 15)
issue_resolution_plans	List<IssueResolutionPlan>	The list of the issue resolution plans of interest (see Table 20, page 37)

Table 20: Attributes of the IssueResolutionPlan class

Name	Type	Description
id	String	The id of the issue resolution plan in hand
time	String	The time, in ISO8601 compliant format, of the publication of the issue resolution plan
snapshot_filename	String	The filename of an image object possibly accompanying the issue resolution plan ²
sector	String	The sector to which the issue resolution plan refers
state	String	The state of the issue resolution plan (submitted, accepted or rejected by the Distribution System Operator - DSO)
aggregator_notes	String	The (optional) notes of the Aggregator
dso_notes	String	The (optional) notes of the DSO
author	String	The author of the issue resolution plan
author_email	String	The email of the author
actions	List<DemandResponseAction>	The list of actions proposed to the DSO (see Table 21, page 37)

Table 21: Attributes of the DemandResponseAction class

Name	Type	Description
target	String	The target of the issue resolution plan action
type	String	The type of the action to be performed (increase, decrease, shift)
value	String	The value of the action to be performed
start_time	String	The start time of the action, in an ISO8601 compliant format
end_time	String	The end time of the action, in an ISO8601 compliant format

2.3.1.1 Retrieve the list of issue resolution plans sharing a common author [GET]

Request

- Headers
 1. x-auth-token: `an_auth_token`
 2. Accept: `application/json`

Response 200 (application/json)

- Body
 1. {
 2. "metadata":{
 3. "api_version":"0.1",
 4. "trial":"Terni",
 5. "created":"2015-01-21T17:48:42+02:00",
 6. "updated":"2015-01-21T17:48:42+02:00"
 7. },
 8. "issue_resolution_plans":[
 9. {

² In the case of the trial site of Terni, this image contains a snapshot of a combined view of the grid issue predictions along with the short-time predicted load for a sector or customer.

```

10.         "id":"IssueResolutionPlan_finesce-wp4-aggregator_140930843
11.         8",
12.         "time":"2014-08-29T13:33:50+03:00",
13.         "snapshot_filename":"RP_finesce-wp4-aggregator_1409308438.
14.         png",
15.         "sector":"LIGHTING",
16.         "action":[
17.             {
18.                 "target":"Energy Consumption",
19.                 "type":"Increase",
20.                 "value":"1.0",
21.                 "start_time":"2014-08-30T00:00:00+03:00",
22.                 "end_time":"2014-09-01T23:30:00+03:00"
23.             },
24.             {
25.                 "target":"Energy Production",
26.                 "type":"Decrease",
27.                 "value":"2.0",
28.                 "start_time":"2014-08-30T00:00:00+03:00",
29.                 "end_time":"2014-09-01T23:30:00+03:00"
30.             }
31.         ],
32.         "state":"approved",
33.         "aggregator_notes":"-",
34.         "dso_notes":"-",
35.         "author":"finesce-wp4-aggregator",
36.         "author_email":"email@email.com"
37.     },
38.     .....
39.     {
40.         "id":"IssueResolutionPlan_finesce-wp4-aggregator_141647322
41.         1",
42.         "time":"2014-11-20T10:46:59+02:00",
43.         "snapshot_filename":"RP_finesce-wp4-aggregator_1416473221.
44.         png",
45.         "sector":"ALL",
46.         "action":[
47.             {
48.                 "target":"Energy Consumption",
49.                 "type":"Increase",
50.                 "value":"2.0",
51.                 "start_time":"2014-11-20T10:00:00+02:00",
52.                 "end_time":"2014-11-20T15:00:00+02:00"
53.             }
54.         ],
55.         "state":"submitted",
56.         "aggregator_notes":"-",
57.         "dso_notes":"none",
58.         "author":"finesce-wp4-aggregator",
59.         "author_email":"email@email.com"
60.     }
61. ]
62. }

```

2.3.2 Get the list of issue resolution plans sharing a common state

Endpoint URL: `[/{version}/{trial}/dsm/irp/state/{state}]`

Allows a user to get a list of issue resolution plans based on their state. 'Terni' is the only trial offering this service.

Parameters

Name	Type	Example	Description
<i>version</i>	String	v0.1	The version of the API to use.
<i>trial</i>	String	Terni	The trial infrastructure to use for invoking the respective service.
<i>state</i>	String	submitted	The state of the issue resolution plans.

The class diagram of the response (instance of an IssueResolutionPlanResponse class) is presented in Figure 14, page 36.

2.3.2.1 Retrieve the list of issue resolution plans sharing a common state [GET]

Request

- Headers
 1. x-auth-token: `an_auth_token`
 2. Accept: `application/json`

Response 200 (application/json)

- Body
 1. {
 2. "metadata":{
 3. "api_version":"0.1",
 4. "trial":"Terni",
 5. "created":"2015-01-21T17:50:42+02:00",
 6. "updated":"2015-01-21T17:50:42+02:00"
 7. },
 8. "issue_resolution_plans":[
 9. {
 10. "id":"IssueResolutionPlan_finesce-wp4-aggregator_140930843
 11. "8",
 12. "time":"2014-08-29T13:33:50+03:00",
 13. "snapshot_filename":"RP_finesce-wp4-aggregator_1409308438.
 14. "png",
 15. "sector":"LIGHTING",
 16. "action":[
 17. {
 18. "target":"Energy Consumption",
 19. "type":"Increase",
 20. "value":"1.0",
 21. "start_time":"2014-08-30T00:00:00+03:00",
 22. "end_time":"2014-09-01T23:30:00+03:00"
 23. },
 24. {
 25. "target":"Energy Production",
 26. "type":"Decrease",
 27. "value":"2.0",
 28. "start_time":"2014-08-30T00:00:00+03:00",
 29. "end_time":"2014-09-01T23:30:00+03:00"
 30. }
 31. }
 32.]
 33. }

```

29.         ],
30.         "state": "submitted",
31.         "aggregator_notes": "-",
32.         "dso_notes": "none",
33.         "author": "finesce-wp4-aggregator",
34.         "author_email": "email@email.com"
35.     },
36.     .....
37.     {
38.         "id": "IssueResolutionPlan_finesce-wp4-aggregator_141647322
39.         1",
40.         "time": "2014-11-20T10:46:59+02:00",
41.         "snapshot_filename": "RP_finesce-wp4-aggregator_1416473221.
42.         png",
43.         "sector": "ALL",
44.         "action": [
45.             {
46.                 "target": "Energy Consumption",
47.                 "type": "Increase",
48.                 "value": "2.0",
49.                 "start_time": "2014-11-20T10:00:00+02:00",
50.                 "end_time": "2014-11-20T15:00:00+02:00"
51.             }
52.         ],
53.         "state": "submitted",
54.         "aggregator_notes": "-",
55.         "dso_notes": "none",
56.         "author": "finesce-wp4-aggregator",
57.         "author_email": "email@email.com"
58.     }
59. ]
60. }

```

2.3.3 Get the list of issue resolution plans sharing common authors and states

Endpoint URL: `[/]{version}/{trial}/dsm/irp/author/{author}/state/{state}]`

Allows a user to get a list of issue resolution plans based on their state and author. 'Terni' is the only trial offering this service.

Parameters

Name	Type	Example	Description
<i>version</i>	String	v0.1	The version of the API to use.
<i>trial</i>	String	Terni	The trial infrastructure to use for invoking the respective service.
<i>author</i>	String	finesce-wp4-aggregator	The author (aggregator) of the issue resolution plans.
<i>state</i>	String	submitted	The state of the issue resolution plans.

The class diagram of the response (instance of an `IssueResolutionPlanResponse` class) is presented in Figure 14, page 36.

2.3.3.1 Retrieve the list of issue resolution plans sharing common authors and states [GET]

Request

- Headers
 1. x-auth-token: `an_auth_token`
 2. Accept: `application/json`

Response 200 (application/json)

- Body
 1. {
 2. "metadata":{
 3. "api_version":"0.1",
 4. "trial":"Terni",
 5. "created":"2015-01-21T17:52:02+02:00",
 6. "updated":"2015-01-21T17:52:02+02:00"
 7. },
 8. "issue_resolution_plans":[
 9. {
 10. "id":"IssueResolutionPlan_finesce-wp4-aggregator_140930843
 11. 8",
 12. "time":"2014-08-29T13:33:50+03:00",
 13. "snapshot_filename":"RP_finesce-wp4-aggregator_1409308438.
 14. png",
 15. "sector":"LIGHTING",
 16. "action":[
 17. {
 18. "target":"Energy Consumption",
 19. "type":"Increase",
 20. "value":"1.0",
 21. "start_time":"2014-08-30T00:00:00+03:00",
 22. "end_time":"2014-09-01T23:30:00+03:00"
 23. },
 24. {
 25. "target":"Energy Production",
 26. "type":"Decrease",
 27. "value":"2.0",
 28. "start_time":"2014-08-30T00:00:00+03:00",
 29. "end_time":"2014-09-01T23:30:00+03:00"
 30. }
 31.],
 32. "state":"submitted",
 33. "aggregator_notes":"-",
 34. "dso_notes":"none",
 35. "author":"finesce-wp4-aggregator",
 36. "author_email":"email@email.com"
 37. },
 38.
 39. {
 40. "id":"IssueResolutionPlan_finesce-wp4-aggregator_141647322
 41. 1",
 42. "time":"2014-11-20T10:46:59+02:00",
 43. "snapshot_filename":"RP_finesce-wp4-aggregator_1416473221.
 44. png",
 45. "sector":"ALL",
 46. "action":[
 47. {
 48. "target":"Energy Consumption",

```

45.         "type": "Increase",
46.         "value": "2.0",
47.         "start_time": "2014-11-20T10:00:00+02:00",
48.         "end_time": "2014-11-20T15:00:00+02:00"
49.     }
50. ],
51. "state": "submitted",
52. "aggregator_notes": "-",
53. "dso_notes": "none",
54. "author": "finesce-wp4-aggregator",
55. "author_email": "email@email.com"
56. }
57. ]
58. }

```

2.3.4 Get the list of incentive plans sharing a common author

Endpoint URL: `[/{version}]/{trial}/dsm/ip/author/{author}`

Allows an energy retailer to get a list of incentive plans based on their author name. 'Terni' is the only trial offering this service.

Parameters

<i>Name</i>	<i>Type</i>	<i>Example</i>	<i>Description</i>
<i>version</i>	String	v0.1	The version of the API to use.
<i>trial</i>	String	Terni	The trial infrastructure to use for invoking the respective service.
<i>author</i>	String	energy-retailer	The author (aggregator) of the incentive plans.

The class diagram of the response (instance of an IncentivePlanReport class) follows in Figure 15.

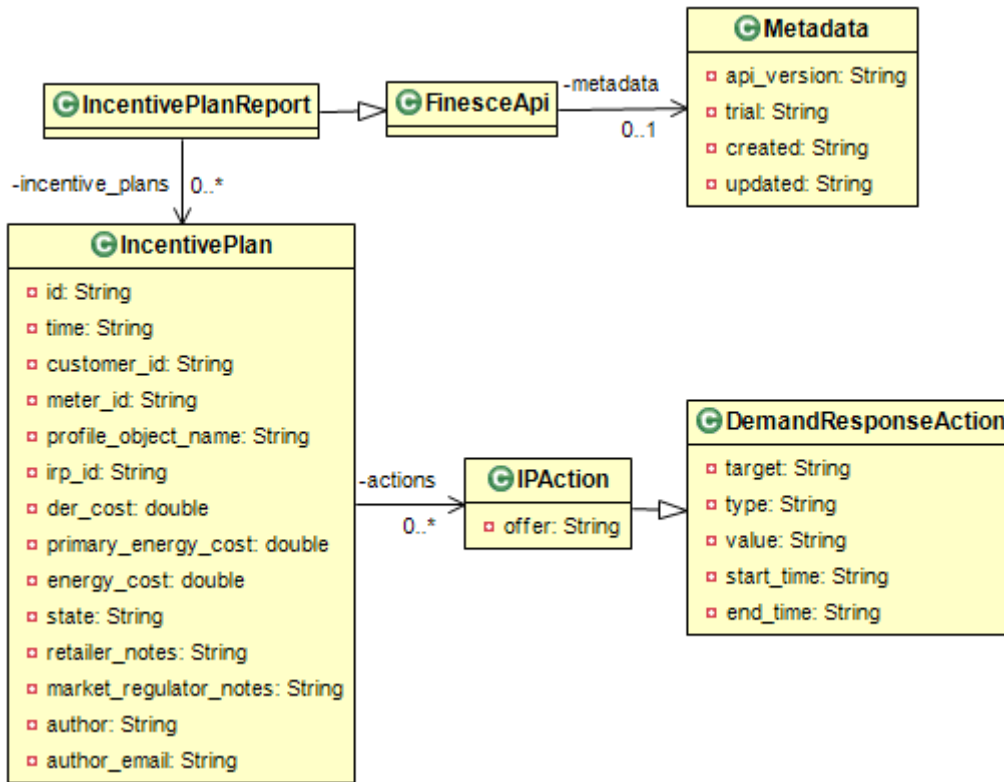

Figure 15: Class diagram of an IncentivePlanReport response

The detailed description of the relevant class attributes also follows in the forthcoming tables.

Table 22: Attributes of the IncentivePlanReport class

Name	Type	Description
metadata	Metadata	The metadata of the report (see Table 5, page 15)
incentive_plans	List<IncentivePlan>	The list of the incentive plans of interest (see Table 23, page 43)

Table 23: Attributes of the IncentivePlan class

Name	Type	Description
id	String	The id of the incentive plan
time	String	The time of the publication of the incentive plan, in an ISO8601 compliant format
customer_id	String	The id of the customer the incentive plan refers to
meter_id	String	The id of the metering device associated with the aforementioned customer
profile_object_name	String	
irp_id	String	The id of the issue resolution plan this incentive plan addresses
der_cost	double	The cost of the energy produced by renewable sources
primary_energy_cost	double	The cost of the energy produced by traditional methods, at very large scale (e.g. coal)
energy_cost	double	The final cost of the energy attained by the customer
state	String	The state of the incentive plan (Submitted, Compliant or Non-Compliant)
retailer_notes	String	The (optional) notes posed by the energy retailer upon publishing the incentive plan
market_regulator_notes	String	The (optional) notes posed by the market

		regulator upon evaluating the incentive plan
author	String	The author of the incentive plan
author_email	String	The email of the author
actions	List <IPAction>	A list of actions proposed to the customer associated with the incentive plan in hand (see Table 24, unterhalb)

Table 24: Attributes of the IPAction class

Name	Type	Description
target	String	The target of the issue resolution plan action
type	String	The type of the action to be performed (increase, decrease, shift)
value	String	The value of the action to be performed
start_time	String	The start time of the action, in an ISO8601 compliant format
end_time	String	The end time of the action, in an ISO8601 compliant format
offer	String	The offer (incentive) of the energy retailer to the customer

Note that the IPAction class subclasses the DemandResponseAction class (see Table 21, page 37), hence sharing common attributes.

2.3.4.1 Retrieve the list of incentive plans sharing a common author [GET]

Request

- Headers
 1. x-auth-token: `an_auth_token`
 2. Accept: `application/json`

Response 200 (application/json)

- Body
 1. {
 2. "metadata":{
 3. "api_version":"0.1",
 4. "trial":"Terni",
 5. "created":"2015-02-09T15:55:29+01:00",
 6. "updated":"2015-02-09T15:55:29+01:00"
 7. },
 8. "incentive_plans":[
 9. {
 10. "id":"IncentivePlan_energy-retailer_1423145897",
 11. "time":"2015-02-05T15:18:17+01:00",
 12. "customer_id":"WP4_U_3",
 13. "meter_id":"",
 14. "profile_object_name":"-",
 15. "irp_id":"IssueResolutionPlan_finesce-wp4-aggregator_1423076125",
 16. "action":[
 17. {
 18. "target":"Energy Consumption",
 19. "type":"Increase",
 20. "value":"2.0",
 21. "start_time":"2015-02-04T20:00:00+01:00",
 22. "end_time":"2015-02-05T08:00:00+01:00"
 23. }

```

24.     ],
25.     "der_cost":0,
26.     "primary_energy_cost":0,
27.     "energy_cost":0,
28.     "state":"Submitted",
29.     "retailer_notes":"Limited time offer",
30.     "market_regulator_notes":"-",
31.     "author":"energy-retailer",
32.     "author_email":"-"
33.   },
34.   {
35.     "id":"IncentivePlan_energy-retailer_1423211072",
36.     "time":"2015-02-06T09:24:32+01:00",
37.     "customer_id":"WP4_U_3",
38.     "meter_id":"",
39.     "profile_object_name":"-",
40.     "irp_id":"IssueResolutionPlan_finesce-wp4-
aggregator_1416413747",
41.     "action":[
42.       {
43.         "target":"Energy Consumption",
44.         "type":"Decrease",
45.         "value":"5.0",
46.         "start_time":"2014-11-21T17:30:00+01:00",
47.         "end_time":"2014-11-22T17:30:00+01:00"
48.       }
49.     ],
50.     "der_cost":0,
51.     "primary_energy_cost":0,
52.     "energy_cost":0,
53.     "state":"Compliant",
54.     "retailer_notes":"-",
55.     "market_regulator_notes":"OK",
56.     "author":"energy-retailer",
57.     "author_email":"-"
58.   }
59. ]
60. }

```

2.3.5 Get the list of incentive plans sharing a common state

Endpoint URL: `[/{version}]/{trial}/dsm/ip/state/{state}`

Allows an energy retailer to get a list of incentive plans based on their state. 'Terni' is the only trial offering this service.

Parameters

Name	Type	Example	Description
<i>version</i>	String	v0.1	The version of the API to use.
<i>trial</i>	String	Terni	The trial infrastructure to use for invoking the respective service.
<i>state</i>	String	Compliant	The state of the incentive plans.

The class diagram of the response (instance of an IncentivePlanReport class) has been already provided in Figure 15, page 43.

2.3.5.1 Retrieve the list of incentive plans sharing a common state [GET]

Request

- Headers
 1. x-auth-token: `an_auth_token`
 2. Accept: `application/json`

Response 200 (application/json)

- Body
 1. {
 2. "metadata":{
 3. "api_version":"0.1",
 4. "trial":"Terni",
 5. "created":"2015-02-27T12:11:05+02:00",
 6. "updated":"2015-02-27T12:11:05+02:00"
 7. },
 8. "incentive_plans":[
 9. {
 10. "id":"IncentivePlan_energy-retailer_1423145897",
 11. "time":"2015-02-05T16:18:17+02:00",
 12. "customer_id":"WP4_U_3",
 13. "meter_id":"0512690040067",
 14. "profile_object_name":"-",
 15. "irp_id":"IssueResolutionPlan_finesce-wp4-aggregator_1423076125",
 16. "actions":[
 17. {
 18. "target":"Energy Consumption",
 19. "type":"Increase",
 20. "value":"2.0",
 21. "start_time":"2015-02-04T21:00:00+02:00",
 22. "end_time":"2015-02-05T09:00:00+02:00",
 23. "offer":"100E free"
 24. }
 25.],
 26. "der_cost":0.0,
 27. "primary_energy_cost":0.0,
 28. "energy_cost":0.0,
 29. "state":"Compliant",
 30. "retailer_notes":"Limited time offer",
 31. "market_regulator_notes":"OK OK",
 32. "author":"energy-retailer",
 33. "author_email":"-"
 34. },
 35. {
 36. "id":"IncentivePlan_energy-retailer_1423578590",
 37. "time":"2015-02-10T16:33:25+02:00",
 38. "customer_id":"WP4_U_14",
 39. "meter_id":"0512690040069",
 40. "profile_object_name":"-",
 41. "irp_id":"IssueResolutionPlan_finesce-wp4-aggregator_1423220983",
 42. "actions":[
 43. {
 44. "target":"Energy Consumption",

```

45.         "type": "Increase",
46.         "value": "2.0",
47.         "start_time": "2015-02-08T01:00:00+02:00",
48.         "end_time": "2015-02-10T01:00:00+02:00",
49.         "offer": "Two free monts"
50.     }
51. ],
52.     "der_cost": 0.0,
53.     "primary_energy_cost": 0.0,
54.     "energy_cost": 0.0,
55.     "state": "Compliant",
56.     "retailer_notes": "-",
57.     "market_regulator_notes": "OK OK",
58.     "author": "energy-retailer",
59.     "author_email": "-"
60. }
61. ]
62. }

```

2.3.6 Get the list of incentive plans sharing common authors and states

Endpoint URL: `[/{version}/{trial}/dsm/ip/author/{author}/state/{state}]`

Allows an energy retailer to get a list of incentive plans based on their state and author. 'Terni' is the only trial offering this service.

Parameters

Name	Type	Example	Description
<i>version</i>	String	v0.1	The version of the API to use.
<i>trial</i>	String	Terni	The trial infrastructure to use for invoking the respective service.
<i>author</i>	String	energy-retailer	The author (aggregator) of the incentive plans.
<i>state</i>	String	Compliant	The state of the incentive plans.

The class diagram of the response (instance of an IncentivePlanReport class) has been already provided in Figure 15, page 43.

2.3.6.1 Retrieve the list of incentive plans sharing common authors and states [GET]

Request

- Headers
 1. x-auth-token: `an_auth_token`
 2. Accept: `application/json`

Response 200 (application/json)

- Body
 1. {
 2. "metadata": {

```
3.     "api_version":"0.1",
4.     "trial":"Terni",
5.     "created":"2015-02-27T12:11:05+02:00",
6.     "updated":"2015-02-27T12:11:05+02:00"
7. },
8.   "incentive_plans":[
9.     {
10.      "id":"IncentivePlan_energy-retailer_1423145897",
11.      "time":"2015-02-05T16:18:17+02:00",
12.      "customer_id":"WP4_U_3",
13.      "meter_id":"0512690040067",
14.      "profile_object_name":"-",
15.      "irp_id":"IssueResolutionPlan_finesce-wp4-
16. aggregator_1423076125",
17.      "actions":[
18.        {
19.          "target":"Energy Consumption",
20.          "type":"Increase",
21.          "value":"2.0",
22.          "start_time":"2015-02-04T21:00:00+02:00",
23.          "end_time":"2015-02-05T09:00:00+02:00",
24.          "offer":"100E free"
25.        }
26.      ],
27.      "der_cost":0.0,
28.      "primary_energy_cost":0.0,
29.      "energy_cost":0.0,
30.      "state":"Compliant",
31.      "retailer_notes":"Limited time offer",
32.      "market_regulator_notes":"OK OK",
33.      "author":"energy-retailer",
34.      "author_email":"-"
35.    },
36.    {
37.      "id":"IncentivePlan_energy-retailer_1423578590",
38.      "time":"2015-02-10T16:33:25+02:00",
39.      "customer_id":"WP4_U_14",
40.      "meter_id":"0512690040069",
41.      "profile_object_name":"-",
42.      "irp_id":"IssueResolutionPlan_finesce-wp4-
43. aggregator_1423220983",
44.      "actions":[
45.        {
46.          "target":"Energy Consumption",
47.          "type":"Increase",
48.          "value":"2.0",
49.          "start_time":"2015-02-08T01:00:00+02:00",
50.          "end_time":"2015-02-10T01:00:00+02:00",
51.          "offer":"Two free monts"
52.        }
53.      ],
54.      "der_cost":0.0,
55.      "primary_energy_cost":0.0,
56.      "energy_cost":0.0,
57.      "state":"Compliant",
58.      "retailer_notes":"-",
59.      "market_regulator_notes":"OK OK",
60.      "author":"energy-retailer",
61.      "author_email":"-"
```



```

60.     }
61.   ]
62. }
    
```

2.3.7 Get the contracts corresponding to a customer, regardless of their state

Endpoint URL: `[/{version}/{trial}/contracts/customer/{customer}]`

Allows an energy retailer to get the list of contracts corresponding to a specific customer, regardless of their state. 'Terni' is the only trial offering this service.

Parameters

Name	Type	Example	Description
<i>version</i>	String	v0.1	The version of the API to use.
<i>trial</i>	String	Terni	The trial infrastructure to use for invoking the respective service.
<i>customer</i>	String	WP4_U_11	The customer for which the contracts details will be retrieved.

The class diagram of the response (instance of a ContractReport class) is presented in Figure 16, below.

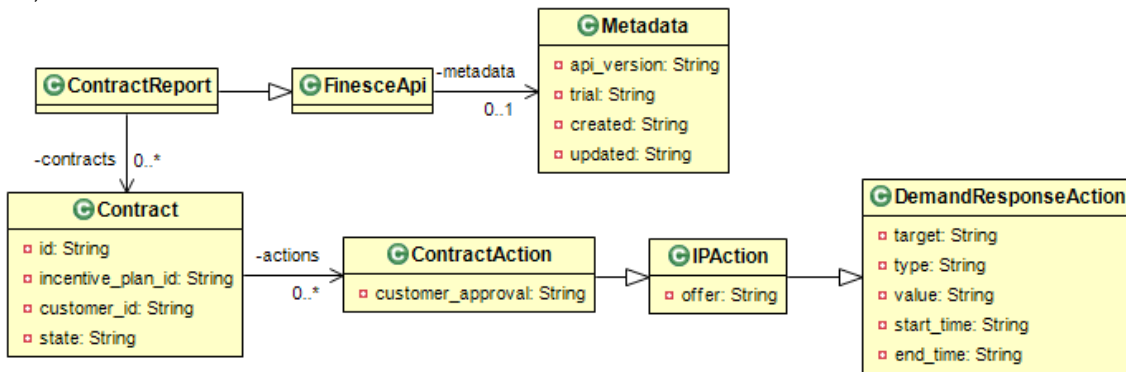

Figure 16: Class diagram of a ContractReport response.

Table 25: Attributes of the ContractReport class.

Name	Type	Description
metadata	Metadata	The metadata of the report (see Table 5, page 15)
contracts	List<Contract>	The list of the contracts of interest (see Table 26, page 49)

Table 26: Attributes of the Contract class.

Name	Type	Description
id	String	The id of the contract in hand
incentive_plan_id	String	The id of the incentive plan corresponding to the contract
customer_id	String	The id of the customer associated with the contract
state	String	The state of the contract (Submitted, Approved or rejected)
actions	List<ContractAction>	The list of actions proposed to the customer

Table 27: Attributes of the ContractAction class.

Name	Type	Description
target	String	The target of the issue resolution plan action
type	String	The type of the action to be performed (increase, decrease, shift)
value	String	The value of the action to be performed
start_time	String	The start time of the action, in an ISO8601 compliant format
end_time	String	The end time of the action, in an ISO8601 compliant format
offer	String	The offer (incentive) of the energy retailer to the customer
customer_approval	String	Indicates when the customer decided (approved or rejected) the contract

Note that a ContractAction actually extends the already presented IPAction class (see Table 24, page 44), so it also comprises the attributes of this class as well.

2.3.7.1 Retrieve the contracts corresponding to a customer, regardless of their state [GET]

Request

- Headers
 1. x-auth-token: `an_auth_token`
 2. Accept: `application/json`

Response 200 (application/json)

- Body
 1. {
 2. "metadata":{
 3. "api_version":"0.1",
 4. "trial":"Terni",
 5. "created":"2015-01-22T14:34:44+02:00",
 6. "updated":"2015-01-22T14:34:44+02:00"
 7. },
 8. "contract":[
 9. {
 10. "id":null,
 11. "incentive_plan_id":null,
 12. "customer_id":"WP4_U_11",
 13. "action":[
 14.],
 15. "state":null
 16. }
 17.]
 18. }
 19. }

2.3.8 Get the contracts corresponding to a customer, characterized by a specific state

Endpoint URL: `[/{version}]/{trial}/contracts/customer/{customer}/state/{state}]`

Allows an energy retailer to get the list of contracts corresponding to a specific customer, regardless of their state. 'Terni' is the only trial offering this service.

Parameters

Name	Type	Example	Description
<i>version</i>	String	v0.1	The version of the API to use.
<i>trial</i>	String	Terni	The trial infrastructure to use for invoking the respective service.
<i>customer</i>	String	WP4_U_11	The customer for which the contracts details will be retrieved.
<i>state</i>	String	Approved	The state of the contracts to be retrieved.

The class diagram of the response (instance of a ContractReport class) has been already presented in Figure 16, page 49.

2.3.8.1 Retrieve the contracts corresponding to a customer, characterized by a specific state [GET]

Request

- Headers
 1. x-auth-token: `an_auth_token`
 2. Accept: `application/json`

Response 200 (application/json)

- Body
 1. {
 2. "metadata":{
 3. "api_version":"0.1",
 4. "trial":"Terni",
 5. "created":"2015-01-22T14:34:44+02:00",
 6. "updated":"2015-01-22T14:34:44+02:00"
 7. },
 8. "contract":[
 9. {
 10. "id":null,
 11. "incentive_plan_id":null,
 12. "customer_id":null,
 13. "action":[
 14.],
 15. "state":"Approved"
 16. }
 17.]
 18. }
 19. }

2.3.9 Get the contracts corresponding to a customer, characterized by a specific state

Endpoint URL: `[/{version}/{trial}/contracts/customer/{customer}/state/{state}]`

Allows an energy retailer to get the list of contracts sharing a common state. 'Terni' is the only trial offering this service.

Parameters

<i>Name</i>	<i>Type</i>	<i>Example</i>	<i>Description</i>
<i>version</i>	String	v0.1	The version of the API to use.
<i>trial</i>	String	Terni	The trial infrastructure to use for invoking the respective service.
<i>state</i>	String	Approved	The state of the contracts to be retrieved.

The class diagram of the response (instance of a ContractReport class) has been already presented in Figure 16, page 49.

2.3.9.1 Retrieve a list of contracts sharing a common state [GET]**Request**

- Headers
 1. x-auth-token: `an_auth_token`
 2. Accept: `application/json`

Response 200 (application/json)

- Body
 1. {
 2. "metadata":{
 3. "api_version":"0.1",
 4. "trial":"Terni",
 5. "created":"2015-01-22T14:34:44+02:00",
 6. "updated":"2015-01-22T14:34:44+02:00"
 7. },
 8. "contract":[
 9. {
 10. "id":null,
 11. "incentive_plan_id":null,
 12. "customer_id":"WP4_U_11",
 13. "action":[
 14.],
 15. "state":"Approved"
 16. }
 17.]
 18. }
 19. }

2.3.10 Get the user-contracted energy prices

Endpoint URL: `[/{version}/{trial}/contracts/prices]`

Allows a user to get the contracted prices for electricity, based on their type. 'Terni' is the only trial offering this service.

Parameters

<i>Name</i>	<i>Type</i>	<i>Example</i>	<i>Description</i>
-------------	-------------	----------------	--------------------

<i>version</i>	String	v0.1	The version of the API to use.
<i>trial</i>	String	Terni	The trial infrastructure to use for invoking the respective service.

The class diagram of the Response (EnergyCostsReport) follows.

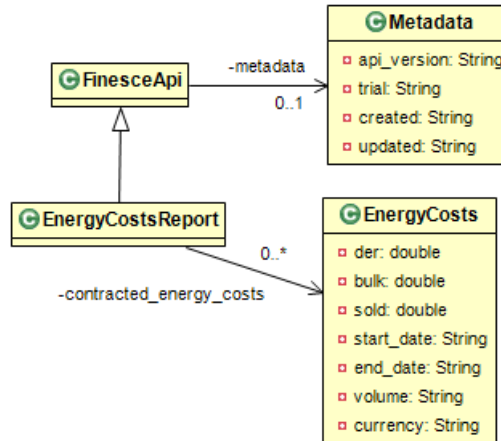

Figure 17: Class diagram of an EnergyCostsReport response

The attributes of the referenced classes are as follows:

Table 28: Attributes of the EnergyCostsReport class

Name	Type	Description
metadata	Metadata	The metadata of the report (see Table 5, page 15)
contracted_energy_costs	List<EnergyCosts>	The list of the present contracted energy costs (see Table 29, page 53)

Table 29: Attributes of the EnergyCosts class

Name	Type	Description
der	double	The cost of the energy coming from renewable energy sources
bulk	double	The cost of the energy coming from bulk generation sources (e.g. coal)
sold	double	The cost of the energy actually sold to the customers
volume	String	The metric of the energy (e.g. kWh)
currency	String	The currency of the energy sold (default is €)
start_date	String	The date when the documented prices are valid from, in an ISO8601 compliant format
end_date	String	The date until when the documented prices are valid, in an ISO8601 compliant format

2.3.10.1 Retrieve the user-contracted energy prices [GET]

Request

- Headers
 1. x-auth-token: *an_auth_token*
 2. Accept: *application/json*

Response 200 (application/json)

- Body

```
1. {
2.   "metadata":{
3.     "api_version":"0.1",
4.     "trial":"Terni",
5.     "created":"2015-02-09T18:17:13+01:00",
6.     "updated":"2015-02-09T18:17:13+01:00"
7.   },
8.   "contracted_energy_cost":[
9.     {
10.      "der":0,
11.      "bulk":0,
12.      "sold":0,
13.      "start_date":"1970-01-01T01:00:00+01:00",
14.      "end_date":"1970-01-01T01:00:00+01:00",
15.      "volume":"kWh",
16.      "currency":"Euro"
17.    }
18.  ]
19. }
```

2.4 Discrete Time Support

This API set offers services related to supporting discrete timeslots for describing an energy report instead using of continuous entities related to normal, continuous date/time presentation.

2.4.1 Get the available timeslots

Endpoint URL: [/{version}/{trial}/timeslots]

Allows a user to retrieve a list of the valid timeslots in the trial infrastructure. 'Ireland' is the only trial offering this service.

Parameters

Name	Type	Example	Description
version	String	v0.1	The version of the API to use.
trial	String	Ireland	The trial infrastructure to use for getting the available timeslots.

The class diagram of the response (TimeslotsReport) follows in Figure 18.

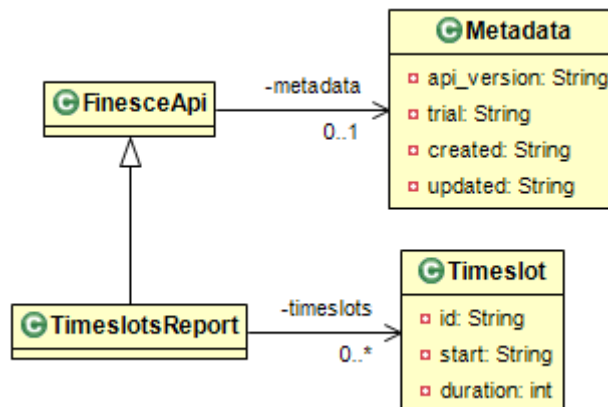

Figure 18: Class diagram of a TimeslotsReport response.

The class attributes of the response class are tabulated below.

Table 30: Attributes of the TimeslotsReport class

Name	Type	Description
metadata	Metadata	The metadata of the report (see Table 5, page 15)
timeslots	List<Timeslot>	The list of the valid timeslots of the trial (see Table 31, page 55)

Table 31: Attributes of the Timeslot class

Name	Type	Description
id	String	The id of the timeslot
start	String	The start time of the timeslot, in an ISO8601 compliant format
duration	String	The duration of the timeslot, in minutes

2.4.1.1 Retrieve the available timeslots [GET]

Request

- Headers
 1. x-auth-token: `an_auth_token`
 2. Accept: `application/json`

Response 200 (application/json)

- Body
 1. {
 2. "metadata":{
 3. "api_version":"0.1",
 4. "trial":"Ireland",
 5. "created":"2015-01-13T13:51:07+02:00",
 6. "updated":"2015-01-13T13:51:07+02:00"
 7. },
 8. "timeslots":[
 9. {
 10. "id":"1",
 11. "start":"2014-12-20T02:15:00+02:00",
 12. "duration":15
 13. },
 14. {
 15. "id":"2",
 16. "start":"2014-12-20T02:30:00+02:00",
 17. "duration":15
 18. }
 19.]
 20. }

2.4.2 Get a timeslots based on its id

Endpoint URL: `/{version}/{trial}/timeslots/{id}`

Allows a user to retrieve a time slot record, based on its id. A valid {id} can be obtained by calling the `/{version}/{trial}/timeslots` service. 'Ireland' is the only trial offering this service.

Parameters

Name	Type	Example	Description
<i>version</i>	String	v0.1	The version of the API to use.
<i>trial</i>	String	Ireland	The trial infrastructure to use for invoking the available timeslots.
<i>id</i>	String	1	The id of the timeslot to get information for.

The class diagram of the response (TimeslotsReport) has been already presented in Figure 18, page 55.

2.4.2.1 Retrieve a timeslot based on its id [GET]

Request

- Headers
 1. x-auth-token: `an_auth_token`
 2. Accept: `application/json`

Response 200 (application/json)

- Body
 1. {
 2. "metadata":{
 3. "api_version":"0.1",
 4. "trial":"Ireland",
 5. "created":"2015-01-13T13:53:21+02:00",
 6. "updated":"2015-01-13T13:53:21+02:00"
 7. },
 8. "timeslots":[
 9. {
 10. "id":"1",
 11. "start":"2014-12-20T02:15:00+02:00",
 12. "duration":15
 13. }
 14.]
 15. }

2.4.3 Get the algorithmic weights associated with a timeslot, based on its id

Endpoint URL: `/{version}/{trial}/timeslots/{id}/algoweights`

Allows a user to retrieve a collection of algorithm weight records associated with a time slot. A valid {id} can be obtained by calling the `/{version}/{trial}/timeslots` service. 'Ireland' is the only trial offering this service.

Parameters

Name	Type	Example	Description
<i>version</i>	String	v0.1	The version of the API to use.
<i>trial</i>	String	Ireland	The trial infrastructure to use for getting the available algorithm weight objects
<i>id</i>	String	1	The id of the timeslot to get information for.

The class diagram of the response (instance of `AlgoweightReport`) follows in Figure 19.

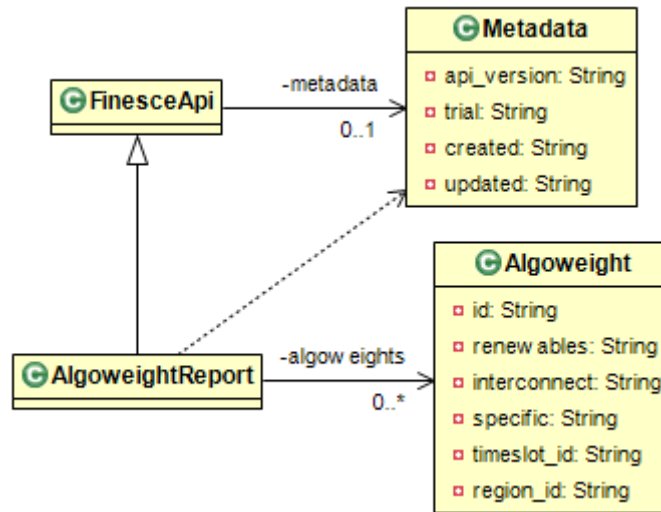

Figure 19: Class diagram of an AlgoweightReport response

The attributes of the class response are presented in the tables, next.

Table 32: Attributes of the AlgoweightReport class

Name	Type	Description
metadata	Metadata	The metadata of the report (see Table 5, page 15)
algoweights	List<Algoweight>	The list of the valid algoweight objects of the trial (see Table 33, page 58)

Table 33: Attributes of the Algoweight class

Name	Type	Description
id	String	The id of the algorithm weight object
renewables	String	The percentage of renewables optimized by the COS algorithm
interconnect	String	The percentage of energy flows among regions, optimized by the COS algorithm
specific	String	The percentage of energy consumed for market requirements optimized by the COS algorithm
timeslot_id	String	The id of the timeslot associated with the algorithm weight object (see Figure 18, page 55)
region_id	String	The id of the region to which the optimization the optimization algorithm weight object refers (see Table 64, page 133)

2.4.3.1 Retrieve the algorithmic weights associated with a timeslot [GET]

Request

- Headers
 1. x-auth-token: **an_auth_token**
 2. Accept: **application/json**

Response 200 (application/json)

- Body
 1. {
 2. "metadata":{
 3. "api_version":"0.1",
 4. "trial":"Ireland",

```

5.     "created": "2015-01-13T14:03:03+02:00",
6.     "updated": "2015-01-13T14:03:03+02:00"
7.   },
8.   "algoweights": [
9.     {
10.      "id": "1",
11.      "renewables": "100.0",
12.      "interconnect": "0.0",
13.      "specific": "0.0",
14.      "timeslot_id": "1",
15.      "region_id": "1"
16.    }
17.  ]
18. }
    
```

2.4.4 Get the charging states associated with a timeslot, based on its id

Endpoint URL: `[/{version}/{trial}/timeslots/{id}/charging_states]`

Allows a user to retrieve a collection of charging state records associated with a time slot, based on its id. A valid {id} can be obtained by calling the `[/{version}/{trial}/timeslots]` service. 'Ireland' is the only trial offering this service.

Parameters

Name	Type	Example	Description
<i>version</i>	String	v0.1	The version of the API to use.
<i>trial</i>	String	Ireland	The trial infrastructure to use for getting the available charging states.
<i>id</i>	String	1	The id of the timeslot to get information for.

The class diagram of the response ((instance of ChargingStatesReport) is presented in Figure 20.

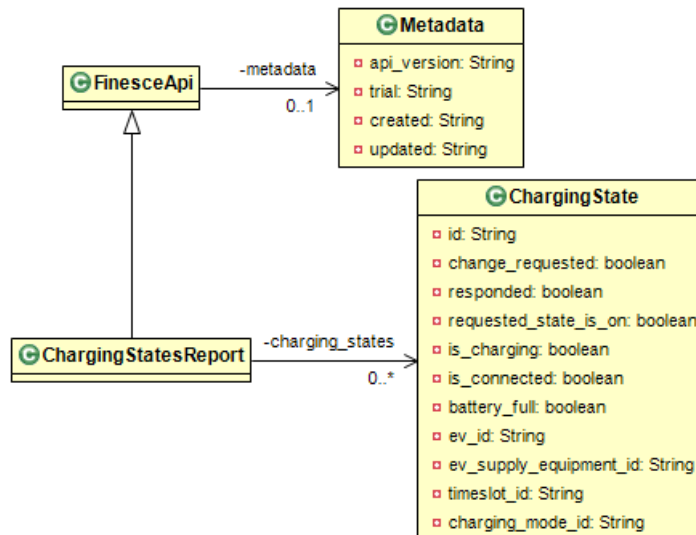

Figure 20: Class diagram of a ChargingStatesReport response.

The attributes of the response follow in the forthcoming tables.

Name	Type	Description
------	------	-------------

metadata	Metadata	The metadata of the report (see Table 5, page 15)
timeslots	List<ChargingState>	The list of the charging states of the trial (see Table 31, page 55)

Name	Type	Description
id	String	The id of the charging state instance
change_requested	Boolean	Indicates if a state change has been requested
responded	Boolean	The response from the servo for the state change
requested_state_is_on	Boolean	The state which has been requested on/off
is_charging	Boolean	Indicates if the electric vehicle is charging
is_connected	Boolean	Indicates if the electric vehicle is connected to an electric vehicle supply equipment
battery_full	Boolean	Indicates if the vehicle battery is full
ev_id	String	The electric vehicle id (see Figure 22, page 76)
ev_supply_equipment_id	String	The id of the associated electric vehicle supply equipment (see Table 45, page 93)
timeslot_id	String	The id of the timeslot associate with this charging state instance
charging_mode_id	String	The id of the charging mode of the electric vehicle (see Table 43, page 90)

2.4.4.1 Retrieve the charging states associated with a timeslot [GET]

Request

- Headers
 1. x-auth-token: `an_auth_token`
 2. Accept: `application/json`

Response 200 (application/json)

- Body
 1. {
 2. "metadata":{
 3. "api_version":"0.1",
 4. "trial":"Ireland",
 5. "created":"2015-01-13T14:06:50+02:00",
 6. "updated":"2015-01-13T14:06:50+02:00"
 7. },
 8. "charging_states":[
 9. {
 10. "id":"1",
 11. "change_requested":false,
 12. "responded":false,
 13. "requested_state_is_on":false,
 14. "is_charging":false,
 15. "is_connected":false,
 16. "battery_full":false,
 17. "ev_id":"1",
 18. "ev_supply_equipment_id":"1",
 19. "timeslot_id":"1",
 20. "charging_mode_id":"1"
 21. }
 22.]
 23. }

2.4.5 Get the EVSE energy records associated with a timeslot, based on its id

Endpoint URL: [/{version}/{trial}/timeslots/{id}/energy/regional]

Allows a user to retrieve a collection of aggregated regional electric vehicle supply equipment (EVSE) energy records associated with a specific timeslot, based on its id. A valid {id} can be obtained by calling the /{version}/{trial}/timeslots service. 'Ireland' is the only trial offering this service.

Parameters

Name	Type	Example	Description
version	String	v0.1	The version of the API to use.
trial	String	Ireland	The trial infrastructure to use for getting the available EVSE energy records for the specific timeslot
id	String	1	The id of the timeslot to get information for.

The class response of the answer (instance of RegionalEnergyReport) follows in the next figure.

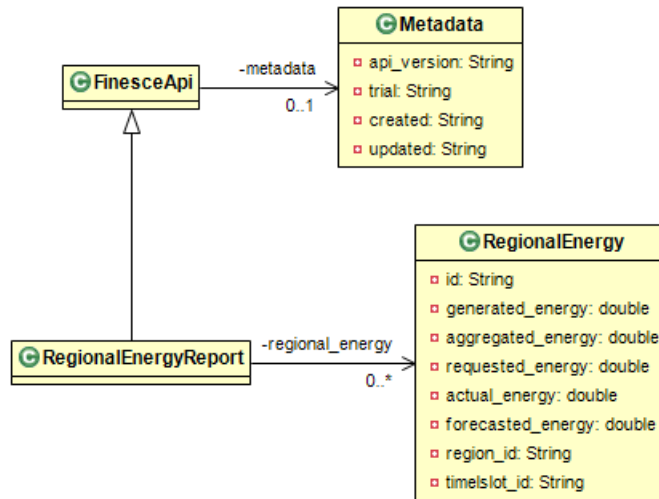

Figure 21: Class diagram of a RegionalEnergyReport response.

Table 34: Attributes of the RegionalEnergyReport class

Name	Type	Description
metadata	Metadata	The metadata of the report (see Table 5, page 15)
regional_energy	List<RegionalEnergy>	The list of the charging states of the trial (see Table 35Table 31, page 61)

Table 35: Attributes of the RegionalEnergy class

Name	Type	Description
id	String	The id of the RegionalEnergy instance
generated_energy	Double	The generated energy in kWh
aggregated_energy	Double	The aggregate energy in kWh
requested_energy	Double	The requested energy in kWh
actual_energy	Double	The actual energy in kWh
forecasted_energy	Double	The forecasted energy in kWh
region_id	String	The id of the region associated with this regional energy reporting (see Table 64, page 133)
timeslot_id	String	The id of the timeslot associated with this regional

2.4.5.1 Retrieve the EVSE energy records associated with a timeslot [GET]

Request

- Headers
 1. x-auth-token: `an_auth_token`
 2. Accept: `application/json`

Response 200 (application/json)

- Body
 1. {
 2. "metadata":{
 3. "api_version":"0.1",
 4. "trial":"Ireland",
 5. "created":"2015-01-13T14:08:23+02:00",
 6. "updated":"2015-01-13T14:08:23+02:00"
 7. },
 8. "regional_energy":[
 9. {
 10. "id":"1",
 11. "generated_energy":5001.57,
 12. "aggregated_energy":6500.36,
 13. "requested_energy":150.69,
 14. "actual_energy":210.67,
 15. "forecasted_energy":6300,
 16. "region_id":"1",
 17. "timeslot_id":"1"
 18. },
 19. {
 20. "id":"2",
 21. "generated_energy":4808.69,
 22. "aggregated_energy":6200,
 23. "requested_energy":178,
 24. "actual_energy":130.78,
 25. "forecasted_energy":6200,
 26. "region_id":"2",
 27. "timeslot_id":"1"
 28. }
 29.]
 30. }

2.5 Energy demand / Power consumption

This API set offers services for getting/updating information related to the electricity demand (consumption).

2.5.1 Get the energy consumption profile of a sector

Endpoint URL: `[/{version}/{trial}/energy/consumption/profile/sector/{sector}/{from}/{to}]`

Retrieves information regarding the energy consumption profile of a specific sector, during a specific time period. A valid {sector} can be obtained by calling the `[/{version}/{trial}/meters/sectors]` service. Valid {from} and {to} values are expressed in ISO8601 format. 'Terni' is the only trial offering this service.

Parameters

Name	Type	Example	Description
<i>version</i>	String	v0.1	The version of the API to use.
<i>trial</i>	String	Terni	The trial infrastructure to use for getting energy consumption profile
<i>sector</i>	String	INDUSTRIAL	The sector to fetch the information for.
<i>from</i>	String	2014-12-20T02:15:00+02:00	The lower limit of the duration of the query, in an ISO8601 compliant format.
<i>to</i>	String	2014-12-20T03:15:00+02:00	The upper limit of the duration of the query, in an ISO8601 compliant format.

The class diagram of the response (instance of MeasurementReport) has already been presented in Figure 10, page 28, using “EnergyConsumptionGrid” as the measurement type.

2.5.1.1 Retrieve the energy consumption profile of a sector [GET]**Request**

• Headers

1. x-auth-token: `an_auth_token`
2. Accept: `application/json`

Response 200 (application/json)

• Body

```

1.   "metadata":{
2.     "api_version":"0.1",
3.     "trial":"Terni",
4.     "created":"2015-01-15T10:46:33+02:00",
5.     "updated":"2015-01-15T10:46:33+02:00"
6.   },
7.   "measurements":[
8.     {
9.       "id":"INDUSTRIAL",
10.      "measurement_type":"EnergyConsumptionGrid",
11.      "values":[
12.        {
13.          "id":null,
14.          "datetime":"2014-12-20T02:15:00+02:00",
15.          "value":277.0
16.        },
17.        {
18.          "id":null,
19.          "datetime":"2014-12-20T02:30:00+02:00",
20.          "value":256.0
21.        },
22.        {
23.          "id":null,
24.          "datetime":"2014-12-20T02:45:00+02:00",
25.          "value":253.0
26.        },
27.        {

```

```

28.         "id":null,
29.         "datetime":"2014-12-20T03:00:00+02:00",
30.         "value":264.0
31.     },
32.     {
33.         "id":null,
34.         "datetime":"2014-12-20T03:15:00+02:00",
35.         "value":236.0
36.     }
37. ],
38. "start_time":"2014-12-20T02:15:00+02:00",
39. "end_time":"2014-12-20T03:15:00+02:00"
40. }
41. ]
42. }

```

2.5.2 Get the energy consumption profile of a user

Endpoint URL:

`[/{version}]/{trial}/energy/consumption/profile/user/{customer_id}/{from}/{to}]`

Retrieves information regarding the energy consumption profile of a specific user, during a specific time period. A valid `{customer_id}` can be obtained by calling the `/{version}}/{trial}/meters` service and checking the 'customer_id' attribute of the response. Valid `{from}` and `{to}` values are expressed in ISO8601 format. 'Terni' is the only trial offering this service.

Parameters

Name	Type	Example	Description
<i>version</i>	String	v0.1	The version of the API to use.
<i>trial</i>	String	Terni	The trial infrastructure to use for getting the energy profile requested
<i>customer_id</i>	String	WP4_U_3	The user to fetch the information for.
<i>from</i>	String	2014-12-20T02:15:00+02:00	The lower limit of the duration of the query, in an ISO8601 compliant format.
<i>to</i>	String	2014-12-20T03:15:00+02:00	The upper limit of the duration of the query, in an ISO8601 compliant format.

The class diagram of the response (instance of MeasurementReport) has already been presented in Figure 10, page 28, using "EnergyConsumptionGrid" as the measurement type.

2.5.2.1 Retrieve the energy consumption profile of a user [GET]

Request

- Headers
 1. x-auth-token: `an_auth_token`
 2. Accept: `application/json`

Response 200 (application/json)

- Body

```

1. {
2.   "metadata":{
3.     "api_version":"0.1",
4.     "trial":"Terni",
5.     "created":"2015-01-15T10:49:06+02:00",
6.     "updated":"2015-01-15T10:49:06+02:00"
7.   },
8.   "measurements":[
9.     {
10.      "id":"WP4_U_3",
11.      "measurement_type":"EnergyConsumptionGrid",
12.      "values":[
13.        {
14.          "id":null,
15.          "datetime":"2014-12-20T02:15:00+02:00",
16.          "value":242.0
17.        },
18.        {
19.          "id":null,
20.          "datetime":"2014-12-20T02:30:00+02:00",
21.          "value":222.0
22.        },
23.        {
24.          "id":null,
25.          "datetime":"2014-12-20T02:45:00+02:00",
26.          "value":219.0
27.        },
28.        {
29.          "id":null,
30.          "datetime":"2014-12-20T03:00:00+02:00",
31.          "value":230.0
32.        },
33.        {
34.          "id":null,
35.          "datetime":"2014-12-20T03:15:00+02:00",
36.          "value":203.0
37.        }
38.      ],
39.      "start_time":"2014-12-20T02:15:00+02:00",
40.      "end_time":"2014-12-20T03:15:00+02:00"
41.    }
42.  ]
43. }

```

2.5.3 Get the total energy consumption of a user

Endpoint URL:

`/[{version}]/{trial}/energy/consumption/total/user/{customer_id}/{from}/{to}`

Retrieves information regarding the total energy consumption of a specific user, during a specific time period. A valid {customer_id} can be obtained by calling the `/[{version}]/{trial}/meters` service and checking the 'customer_id' attribute of the response. Valid {from} and {to} values are expressed in ISO8601 format. 'Terni' is the only trial offering this service.

Parameters

Name	Type	Example	Description
<i>version</i>	String	v0.1	The version of the API to use.
<i>trial</i>	String	Terni	The trial infrastructure to use for getting the requested energy consumption.
<i>customer_id</i>	String	WP4_U_3	The user to fetch the information for.
<i>from</i>	String	2014-12-20T02:15:00+02:00	The lower limit of the duration of the query, in an ISO8601 compliant format.
<i>to</i>	String	2014-12-20T03:15:00+02:00	The upper limit of the duration of the query, in an ISO8601 compliant format.

The class diagram of the response (instance of MeasurementReport) has already been presented in Figure 10, page 28, using “EnergyConsumptionGrid” as the measurement type.

2.5.3.1 Retrieve the total energy consumption of a user [GET]**Request**

- Headers
 1. x-auth-token: `an_auth_token`
 2. Accept: `application/json`

Response 200 (application/json)

- Body
 1. {
 2. "metadata":{
 3. "api_version":"0.1",
 4. "trial":"Terni",
 5. "created":"2015-01-15T10:49:42+02:00",
 6. "updated":"2015-01-15T10:49:42+02:00"
 7. },
 8. "measurements":[
 9. {
 10. "id":"WP4_U_3",
 11. "measurement_type":"EnergyConsumptionGrid",
 12. "values":[
 13. {
 14. "id":null,
 15. "datetime":"1970-01-01T02:00:00+02:00",
 16. "value":1116.0
 17. }
 18.],
 19. "start_time":"2014-12-20T02:15:00+02:00",
 20. "end_time":"2014-12-20T03:15:00+02:00"
 21. }

```

22.     ]
23. }

```

2.5.4 Get the power demand of a user

Endpoint URL: `[/{version}/{trial}/power/demand/user/{customer_id}/{from}/{to}]`

Retrieves information regarding the power demand of a specific user, during a specific time period. A valid {customer_id} can be obtained by calling the `[/{version}/{trial}/meters]` service and checking the 'customer_id' attribute of the response. Valid {from} and {to} values are expressed in ISO8601 format. 'Terni' is the only trial offering this service.

Parameters

Name	Type	Example	Description
<code>version</code>	String	v0.1	The version of the API to use.
<code>trial</code>	String	Terni	The trial infrastructure to use for getting the requested power demand report.
<code>customer_id</code>	String	WP4_U_3	The user to fetch the information for.
<code>from</code>	String	2014-12-20T02:15:00+02:00	The lower limit of the duration of the query, in an ISO8601 compliant format.
<code>to</code>	String	2014-12-20T03:15:00+02:00	The upper limit of the duration of the query, in an ISO8601 compliant format.

The class diagram of the response (instance of MeasurementReport) has already been presented in Figure 10, page 28, using "PowerDemandGrid" as the measurement type.

2.5.4.1 Retrieve the power demand of a user [GET]

Request

- Headers
 1. x-auth-token: `an_auth_token`
 2. Accept: `application/json`

Response 200 (application/json)

- Body
 1. {
 2. "metadata":{
 3. "api_version":"0.1",
 4. "trial":"Terni",
 5. "created":"2015-01-15T21:07:09+02:00",
 6. "updated":"2015-01-15T21:07:09+02:00"
 7. },
 8. "measurements":[
 9. {
 10. "id":"WP4_U_3",
 11. "measurement_type":"PowerDemandGrid",

```

12.         "values":[
13.
14.         ],
15.         "start_time":"2014-12-20T02:15:00+02:00",
16.         "end_time":"2014-12-20T03:15:00+02:00"
17.     }
18. ]
19. }

```

2.6 Energy supply / Power production

This API set offers services for getting/updating information related to the electricity supply (production).

2.6.1 Get the energy production profile of a sector

Endpoint URL: `/{version}/{trial}/energy/production/profile/sector/{sector}/{from}/{to}`

Retrieves information regarding the energy production profile of a specific sector, during a specific time period. A valid {sector} can be obtained by calling the `/{version}/{trial}/meters/sectors` service. Valid {from} and {to} values are expressed in ISO8601 format. 'Terni' is the only trial offering this service.

Parameters

Name	Type	Example	Description
<i>version</i>	String	v0.1	The version of the API to use.
<i>trial</i>	String	Terni	The trial infrastructure to use for getting the requested energy production profile.
<i>sector</i>	String	*	The sector to fetch the information for.
<i>from</i>	String	2014-12-20T02:15:00+02:00	The lower limit of the duration of the query, in an ISO8601 compliant format.
<i>to</i>	String	2014-12-20T03:15:00+02:00	The upper limit of the duration of the query, in an ISO8601 compliant format.

The class diagram of the response (instance of MeasurementReport) has already been presented in Figure 10, page 28, using "EnergyProductionGrid" as the measurement type.

2.6.1.1 Retrieve the energy production profile of a sector [GET]

Request

- Headers
 1. x-auth-token: `an_auth_token`
 2. Accept: `application/json`

Response 200 (application/json)

- Body
 1. {

```

2.   "metadata":{
3.     "api_version":"0.1",
4.     "trial":"Terni",
5.     "created":"2015-01-15T21:09:20+02:00",
6.     "updated":"2015-01-15T21:09:20+02:00"
7.   },
8.   "measurements":[
9.     {
10.      "id":"*",
11.      "measurement_type":"EnergyProductionGrid",
12.      "values":[
13.        {
14.          "id":null,
15.          "datetime":"2014-12-20T02:15:00+02:00",
16.          "value":0.0
17.        },
18.        {
19.          "id":null,
20.          "datetime":"2014-12-20T02:30:00+02:00",
21.          "value":0.0
22.        },
23.        {
24.          "id":null,
25.          "datetime":"2014-12-20T02:45:00+02:00",
26.          "value":0.0
27.        },
28.        {
29.          "id":null,
30.          "datetime":"2014-12-20T03:00:00+02:00",
31.          "value":0.0
32.        },
33.        {
34.          "id":null,
35.          "datetime":"2014-12-20T03:15:00+02:00",
36.          "value":0.0
37.        }
38.      ],
39.      "start_time":"2014-12-20T02:15:00+02:00",
40.      "end_time":"2014-12-20T03:15:00+02:00"
41.    }
42.  ]
43.}

```

2.6.2 Get the energy production profile of a user

Endpoint

URL:

[/{version}/{trial}/energy/production/profile/user/{customer_id}/{from}/{to}]

Retrieves information regarding the energy production profile of a specific user, during a specific time period. A valid {customer_id} can be obtained by calling the /{version}/{trial}/meters service and checking the 'customer_id' attribute of the response. Valid {from} and {to} values are expressed in ISO8601 format. 'Terni' is the only trial offering this service.

Parameters

Name	Type	Example	Description
<i>version</i>	String	v0.1	The version of the API to use.
<i>trial</i>	String	Terni	The trial infrastructure to use for getting the requested energy production profile.
<i>customer_id</i>	String	WP4_U_3	The user to fetch the information for.
<i>from</i>	String	2014-12-20T02:15:00+02:00	The lower limit of the duration of the query, in an ISO8601 compliant format.
<i>to</i>	String	2014-12-20T03:15:00+02:00	The upper limit of the duration of the query, in an ISO8601 compliant format.

The class diagram of the response (instance of MeasurementReport) has already been presented in Figure 10, page 28, using “EnergyProductionGrid” as the measurement type.

2.6.2.1 Retrieve the energy production profile of a user [GET]**Request**

- Headers
 1. x-auth-token: `an_auth_token`
 2. Accept: `application/json`

Response 200 (application/json)

- Body
 1. {
 2. "metadata":{
 3. "api_version":"0.1",
 4. "trial":"Terni",
 5. "created":"2015-01-15T21:11:15+02:00",
 6. "updated":"2015-01-15T21:11:15+02:00"
 7. },
 8. "measurements":[
 9. {
 10. "id":"WP4_U_3",
 11. "measurement_type":"EnergyProductionGrid",
 12. "values":[
 13. {
 14. "id":null,
 15. "datetime":"1970-01-01T02:00:00+02:00",
 16. "value":0.0
 17. }
 18.],
 19. "start_time":"2014-12-20T02:15:00+02:00",
 20. "end_time":"2014-12-20T03:15:00+02:00"

```

21.     }
22.   ]
23. }

```

2.6.3 Get the total energy production of a user

Endpoint URL: `[/{version}/{trial}/energy/production/total/user/{customer_id}/{from}/{to}]`

Retrieves information regarding the total energy production of a specific user, during a specific time period. A valid `{customer_id}` can be obtained by calling the `{version}/{trial}/meters` service and checking the 'customer_id' attribute of the response. Valid `{from}` and `{to}` values are expressed in ISO8601 format. 'Terni' is the only trial offering this service.

Parameters

Name	Type	Example	Description
<code>version</code>	String	v0.1	The version of the API to use.
<code>trial</code>	String	Terni	The trial infrastructure to use for getting the requested energy production report.
<code>customer_id</code>	String	WP4_U_3	The user to fetch the information for.
<code>from</code>	String	2014-12-20T02:15:00+02:00	The lower limit of the duration of the query, in an ISO8601 compliant format.
<code>to</code>	String	2014-12-20T03:15:00+02:00	The upper limit of the duration of the query, in an ISO8601 compliant format.

The class diagram of the response (instance of MeasurementReport) has already been presented in Figure 10, page 28, using "EnergyProductionGrid" as the measurement type.

2.6.3.1 Retrieve the total energy production of a user [GET]

Request

- Headers
 1. x-auth-token: `an_auth_token`
 2. Accept: `application/json`

Response 200 (application/json)

- Body
 1. {
 2. "metadata":{
 3. "api_version":"0.1",
 4. "trial":"Terni",
 5. "created":"2015-01-15T21:11:49+02:00",
 6. "updated":"2015-01-15T21:11:49+02:00"
 7. },
 8. "measurements":[

```

9.      {
10.         "id": "WP4_U_3",
11.         "measurement_type": "EnergyProductionGrid",
12.         "values": [
13.           {
14.             "id": null,
15.             "datetime": "1970-01-01T02:00:00+02:00",
16.             "value": 0.0
17.           }
18.         ],
19.         "start_time": "2014-12-20T02:15:00+02:00",
20.         "end_time": "2014-12-20T03:15:00+02:00"
21.       }
22.   ]
23. }

```

2.6.4 Get the power supply of a user

Endpoint URL: `[/{version}/{trial}/power/supply/user/{customer_id}/{from}/{to}]`

Retrieves information regarding the power supply of a specific user, during a specific time period. A valid {customer_id} can be obtained by calling the `[/{version}/{trial}/meters]` service and checking the 'customer_id' attribute of the response. Valid {from} and {to} values are expressed in ISO8601 format. 'Terni' is the only trial offering this service.

Parameters

Name	Type	Example	Description
<i>version</i>	String	v0.1	The version of the API to use.
<i>trial</i>	String	Terni	The trial infrastructure to use for getting the requested power supply report.
<i>customer_id</i>	String	WP4_U_3	The user to fetch the information for.
<i>from</i>	String	2014-12-20T02:15:00+02:00	The lower limit of the duration of the query, in an ISO8601 compliant format.
<i>to</i>	String	2014-12-20T03:15:00+02:00	The upper limit of the duration of the query, in an ISO8601 compliant format.

The class diagram of the response (instance of MeasurementReport) has already been presented in Figure 10, page 28, using "PowerSupplyGrid" as the measurement type.

2.6.4.1 Retrieve the power supply of a user [GET]

Request

- Headers
 1. x-auth-token: `an_auth_token`
 2. Accept: `application/json`

Response 200 (application/json)

- Body
 1. {
 2. "metadata":{
 3. "api_version":"0.1",
 4. "trial":"Terni",
 5. "created":"2015-01-15T21:12:21+02:00",
 6. "updated":"2015-01-15T21:12:21+02:00"
 7. },
 8. "measurements":[
 9. {
 10. "id":"WP4_U_3",
 11. "measurement_type":"PowerSupplyGrid",
 12. "values":[
 13.],
 14. "start_time":"2014-12-20T02:15:00+02:00",
 15. "end_time":"2014-12-20T03:15:00+02:00"
 16. }
 17.]
 18. }
 19. }

2.6.5 Get the power supply of a building module

Endpoint URL: `[/{version}/{trial}/buildings/{id}/modules/pv/*/PowerSupply/{date}]`

Provides measurements regarding the power generated from a module of a building. Currently, 'pv' is the only module supported. Valid {date} values are expressed in ISO8601 format. 'Madrid' is the only trial offering this service.

Parameters

Name	Type	Example	Description
<i>version</i>	String	v0.1	The version of the API to use.
<i>trial</i>	String	Madrid	The trial infrastructure to use for getting the requested power supply report.
<i>building_id</i>	String	1	The building associated with the module
<i>date</i>	String	2015-02-28T00:00:00+02:00	The date of interest, in an ISO8601 compliant format.

The class diagram of the response (instance of MeasurementReport) has already been presented in Figure 10, page 28, using "PowerSupplyGrid" as the measurement type.

2.6.5.1 Retrieve the power supply of a building module [GET]**Request**

- Headers
 1. Accept: `application/json`

Response 200 (application/json)

- Body
 1. {
 2. "metadata":{
 3. "api_version":"0.1",
 4. "trial":"Madrid",
 5. "created":"2015-02-26T17:33:02+02:00",
 6. "updated":"2015-02-26T17:33:02+02:00"
 7. },
 8. "measurements":{
 9. "measurement_type":"PowerSupplyGrid",
 10. "values":[
 11. {
 12. "id":null,
 13. "datetime":"2015-02-28T00:00:00+02:00",
 14. "value":7551
 15. }
 16.],
 17. "start_time":null,
 18. "end_time":null
 19. }
 20. }

2.6.6 Get the total power of a building module

Endpoint URL: `[/{version}/{trial}/buildings/{id}/modules/inverter/*/PowerMixed/{date}]`

Provides measurements regarding the power generated & consumed (mixed) from a module of a building. Currently, 'inverter' is the only module supported. Valid {date} values are expressed in ISO8601 format. 'Madrid' is the only trial offering this service.

Parameters

Name	Type	Example	Description
<i>version</i>	String	v0.1	The version of the API to use.
<i>trial</i>	String	Madrid	The trial infrastructure to use for getting the requested power supply report.
<i>building_id</i>	String	1	The building associated with the module
<i>date</i>	String	2015-02-28T00:00:00+02:00	The date of interest, in an ISO8601 compliant format.

The class diagram of the response (instance of MeasurementReport) has already been presented in Figure 10, page 28, using "PowerMixed" as the measurement type.

2.6.6.1 Retrieve the total power of a building module [GET]

Request

- Headers
 1. Accept: `application/json`

Response 200 (application/json)

- Body

```
1. {
2.   "metadata":{
3.     "api_version":"0.1",
4.     "trial":"Madrid",
5.     "created":"2015-02-26T17:34:41+02:00",
6.     "updated":"2015-02-26T17:34:41+02:00"
7.   },
8.   "measurements":{
9.     "measurement_type":"PowerMixed",
10.    "values":[
11.      {
12.        "id":null,
13.        "datetime":"2015-02-28T00:00:00+02:00",
14.        "value":6508
15.      }
16.    ],
17.    "start_time":null,
18.    "end_time":null
19.  }
20.}
```

2.7 Electric Vehicles

This group of APIs offers access to information related to monitoring of Electric Vehicles and their supporting equipment.

2.7.1 Get the list of vehicles in trial

Endpoint URL: [/{version}/{trial}/vehicles]

List the vehicles known to the selected trial infrastructure. 'Horsens' and 'Ireland' are the only trials offering this service.

Parameters

Name	Type	Example	Description
version	String	v0.1	The version of the API to use.
trial	String	Horsens	The trial infrastructure to use for invoking the respective service.

The class diagram of the report (instance of VehiclesReport) follows in Figure 22.

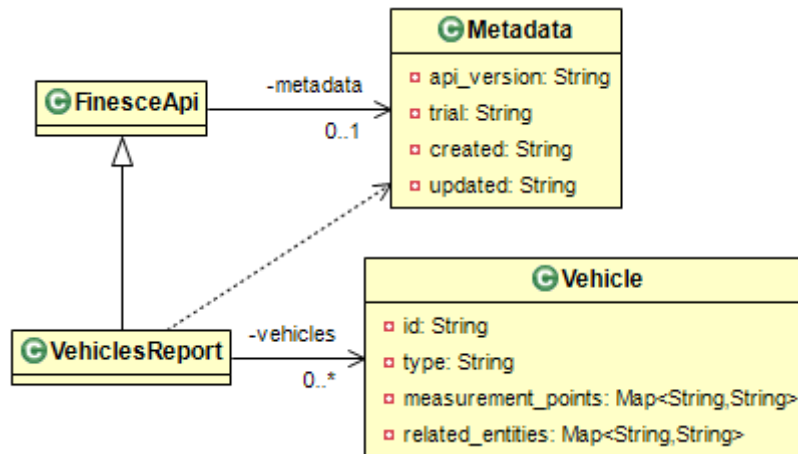

Figure 22: Class diagram of the VehiclesReport class

The attributes of the relevant response class follow:

Table 36: Attributes of the VehiclesReport class

Name	Type	Description
metadata	Metadata	The metadata of the report (see Table 5, page 15)
vehicles	List<Vehicle>	The list of vehicles of interest (see Table 37, page 76)

Table 37: Attributes of the Vehicle class

Name	Type	Description
id	String	The id of the vehicle
type	String	The type of the vehicle
measurement_points	Map<String,String>	The map of capabilities (from a metering point of view) of the vehicle
related_entities_ids	Map<String,String>	The map of related entities (e.g. IDs of related buildings)

2.7.1.1 Retrieve a list of vehicle descriptions [GET]

Request

- Headers
 1. x-auth-token: `an_auth_token`
 2. Accept: `application/json`

Response 200 (application/json)

- Body
 1. {
 2. "metadata":{
 3. "api_version":"0.1",
 4. "trial":"Ireland",
 5. "created":"2015-03-06T11:46:33+02:00",
 6. "updated":"2015-03-06T11:46:33+02:00"
 7. },
 8. "vehicles":[
 9. {
 10. "id":"Vechicle#1234",
 11. "type":"ev-type-1",
 12. "measurement_points":{
 13. "pos-Vechicle#1234":"Position",
 14. "bc-Vechicle#1234":"BatteryCapacity",
 15. "sp-Vechicle#1234":"Speed"
 16. },
 17. "related_entities":{
 18. "1234":"Building"
 19. }
 20. },
 21. {
 22. "id":"Vechicle#4567",
 23. "type":"ev-type-1",
 24. "measurement_points":{
 25. "bc-Vechicle#4567":"BatteryCapacity",
 26. "pos-Vechicle#4567":"Position",
 27. "sp-Vechicle#4567":"Speed"
 28. },
 29. "related_entities":{
 30. "4567":"Building"
 31. }
 32. }
 33.]
 34. }

2.7.2 Get vehicle Description

Endpoint URL: `[/{version}/{trial}/vehicles/{id}]`

GET `/Horsens/vehicles/{id}` Provides information regarding a single vehicle. A valid `{id}` can be found by calling the `[/{version}/{trial}/vehicles]` service. 'Horsens' and 'Ireland' are the only trials offering this service.

Parameters

Name	Type	Example	Description
<i>version</i>	String	v0.1	The version of the API to use.
<i>trial</i>	String	Horsens	The trial infrastructure to use for invoking the respective service.
<i>id</i>	String	Vehicle#1234	The id of the vehicle to be displayed.

The class diagram of the response (instance of VehiclesReport) has been already presented in Figure 22, page 76.

2.7.2.1 Retrieve a description of a single vehicle [GET]**Request**

- Headers
 1. x-auth-token: `an_auth_token`
 2. Accept: `application/json`

Response 200 (application/json)

- Body
 1. {
 2. "metadata":{
 3. "api_version":"0.1",
 4. "trial":"Horsens",
 5. "created":"2015-02-26T16:53:39+02:00",
 6. "updated":"2015-02-26T16:53:39+02:00"
 7. },
 8. "vehicles":[
 9. {
 10. "id":"Vehicle#1234",
 11. "type":"ev-type-1",
 12. "measurement_points":{
 13. "pos-Vehicle#1234":"Position",
 14. "bc-Vehicle#1234":"BatteryCapacity",
 15. "sp-Vehicle#1234":"Speed"
 16. },
 17. "related_entities":{
 18. "1234":"Building"
 19. }
 20. }
 21.]
 22. }

2.7.3 Get vehicles measurement types

Endpoint URL: `[/{version}]/{trial}/vehicles/measurement_types`

Provides a detailed list of all the available vehicle measurements types in the trial. 'Horsens' and 'Ireland' are the only trials offering this service.

Parameters

Name	Type	Example	Description
<i>version</i>	String	v0.1	The version of the API to use.
<i>trial</i>	String	Horsens	The trial infrastructure to use for invoking the respective service.

The class diagram of the response (instance of MeasurementTypesReport) has been already presented in Figure 9, page 23.

2.7.3.1 Retrieve the measurement types of the vehicles of the trial [GET]**Request**

- Headers
 1. x-auth-token: `an_auth_token`
 2. Accept: `application/json`

Response 200 (application/json)

- Body
 1. {
 2. "metadata":{
 3. "api_version":"0.1",
 4. "trial":"Horsens",
 5. "created":"2015-01-07T15:36:03+01:00",
 6. "updated":"2015-01-07T15:36:03+01:00"
 7. },
 8. "measurement_types":[
 9. {
 10. "id":null,
 11. "name":"IndoorTemperatureAverage",
 12. "description":"Indoor temperature average for period",
 13. "type":"Temperature",
 14. "unit":"C"
 15. },
 16. {
 17. "id":null,
 18. "name":"HouseNaturalGasConsumption",
 19. "description":"Accumulated house natural gas consumption f
 20. "or all time",
 21. "type":"Volume",
 22. "unit":"m^3"
 23. },
 24. {
 25. "id":null,
 26. "name":"ICMIndoorCO2LevelAverage",
 27. "description":"Indoor CO2 level average as measured by IC-
 28. "Meter",
 29. "type":"-",
 30. "unit":"ppm"
 31. }
 32.]

31. }

2.7.4 Get vehicles measurement types based on their id

Endpoint URL: `[/{version}/{trial}/vehicles/measurement_types/id/{id}]`

Provides a detailed list of all the available measurements types that match a specific measurements type name. A valid `{id}` can be obtained by calling the `[/{version}/{trial}/vehicles/measurement_types]` service. 'Horsens' and 'Ireland' are the only trials offering this service.

Parameters

Name	Type	Example	Description
<code>version</code>	String	v0.1	The version of the API to use.
<code>trial</code>	String	Horsens	The trial infrastructure to use for invoking the respective service.
<code>id</code>	String	ICMIndoorCO2LevelAverage	The id of the measurement type of interest.

The class diagram of the response (instance of MeasurementTypesReport) has been already presented in Figure 9, page 23.

2.7.4.1 Retrieve a single measurement type based on its id [GET]

Request

- Headers
 1. x-auth-token: `an_auth_token`
 2. Accept: `application/json`

Response 200 (application/json)

- Body
 1. {
 2. "metadata":{
 3. "api_version":"0.1",
 4. "trial":"Horsens",
 5. "created":"2015-01-07T15:40:26+01:00",
 6. "updated":"2015-01-07T15:40:26+01:00"
 7. },
 8. "measurement_types":[
 9. {
 10. "id":null,
 11. "name":"ICMIndoorCO2LevelAverage",
 12. "description":"Indoor CO2 level average as measured by IC-
 13. "Meter",
 14. "type":"-",
 15. "unit":"ppm"
 16. }
 17.]

2.7.5 Get vehicles measurement types based on their general type

Endpoint URL: `[/{version}/{trial}/vehicles/measurement_types/type/{type}]`

Provides a detailed list of all the available measurements types that match a generic measurements type. A valid `{type}` can be obtained by calling the `[/{version}/{trial}/vehicles/measurement_types]` service and check the 'type' entries. 'Horsens' and 'Ireland' are the only trials offering this service.

Parameters

Name	Type	Example	Description
<code>version</code>	String	v0.1	The version of the API to use.
<code>trial</code>	String	Horsens	The trial infrastructure to use for invoking the respective service.
<code>type</code>	String	temperature	The type of the measurement of interest.

The class diagram of the response (instance of MeasurementTypesReport) has been already presented in Figure 9, page 23.

2.7.5.1 Retrieve a single measurement type based on its type [GET]

Request

- Headers
 1. x-auth-token: `an_auth_token`
 2. Accept: `application/json`

Response 200 (application/json)

- Body
 1. {
 2. "metadata":{
 3. "api_version":"0.1",
 4. "trial":"Horsens",
 5. "created":"2015-01-07T15:42:23+01:00",
 6. "updated":"2015-01-07T15:42:23+01:00"
 7. },
 8. "measurement_types":[
 9. {
 10. "id":null,
 11. "name":"IndoorTemperatureAverage",
 12. "description":"Indoor temperature average for period",
 13. "type":"Temperature",
 14. "unit":"C"
 15. }
 16.]
 17. }

2.7.6 Get the available measurement types of a single vehicle

Endpoint URL: `[/{version}/{trial}/vehicles/{id}/measurement_types]`

Provides information regarding the available measurements types for the specific vehicle. A valid {id} can be obtained by calling the `/api/{version}/{trial}/vehicles` service. 'Horsens' and 'Ireland' are the only trials offering this service.

Parameters

Name	Type	Example	Description
<code>version</code>	String	v0.1	The version of the API to use.
<code>trial</code>	String	Horsens	The trial infrastructure to use for invoking the respective service.
<code>id</code>	String	Vehicle#1234	The id of the vehicle of interest.

The class diagram of the response (instance of `MeasurementTypesReport`) has been already presented in Figure 9, page 23.

2.7.6.1 Retrieve the measurement types of a vehicle of the trial [GET]

Request

- Headers
 1. `x-auth-token`: `an_auth_token`
 2. `Accept`: `application/json`

Response 200 (application/json)

- Body
 1. {
 2. "metadata":{
 3. "api_version":"0.1",
 4. "trial":"Horsens",
 5. "created":"2015-01-07T15:45:23+01:00",
 6. "updated":"2015-01-07T15:45:23+01:00"
 7. },
 8. "measurement_types":[
 9. {
 10. "id":null,
 11. "name":"IndoorTemperatureAverage",
 12. "description":"Indoor temperature average for period",
 13. "type":"Temperature",
 14. "unit":"C"
 15. }
 16.]
 17. }

2.7.7 Get the measurements of a single vehicle

Endpoint URL: `/api/{version}/{trial}/vehicles/{id}/measurements/{type_id}/{from}/{to}`

Provides information regarding the available measurements of a specific type for a specific vehicle, during a certain period of time. A valid {id} can be obtained by calling the `/api/{version}/{trial}/vehicles` service. A valid {type_id} can be obtained by calling the `/api/{version}/{trial}/vehicles` service and check the 'measurement_points' section of the answer. Valid {from} and {to} values are expressed in ISO8601 format. 'Horsens' and 'Ireland' are the only trials offering this service.

Parameters

Name	Type	Example	Description
<i>version</i>	String	v0.1	The version of the API to use.
<i>trial</i>	String	Horsens	The trial infrastructure to use for invoking the respective service.
<i>id</i>	String	Vehicle#1234	The id of the vehicle of interest.
<i>type_id</i>	String	IndoorTemperatureAverage	The id of the measurement type to query the building for.
<i>from</i>	String	2014-12-29T19:52:13+02:00	The lower limit of the duration of the query, in an ISO8601 compliant format.
<i>to</i>	String	2014-12-29T20:52:13+02:00	The upper limit of the duration of the query, in an ISO8601 compliant format.

The class diagram of the response (instance of MeasurementReport) has already been presented in Figure 10, page 28, using “IndoorTemperatureAverage” as the measurement type.

2.7.7.1 Retrieve the measurement types of a vehicle of the trial [GET]**Request**

- Headers
 1. x-auth-token: `an_auth_token`
 2. Accept: `application/json`

Response 200 (application/json)

- Body
 1. {
 2. "metadata":{
 3. "api_version":"0.1",
 4. "trial":"Horsens",
 5. "created":"2015-01-12T15:33:30+01:00",
 6. "updated":"2015-01-12T15:33:30+01:00"
 7. },
 8. "measurements":{
 9. "measurement_type":"IndoorTemperatureAverage",
 10. "values":[
 11. {
 12. "id":null,
 13. "datetime":"2015-01-12T15:33:30+01:00",
 14. "value":18
 15. },
 16. {
 17. "id":null,
 18. "datetime":"2015-01-12T15:33:30+01:00",
 19. "value":19

```

20.     }
21.   ],
22.   "start_time":null,
23.   "end_time":null
24. }
25.}
    
```

2.7.8 Get the connections of an EV with an electric vehicle supply equipment component

Endpoint URL: [/]{version}/{trial}/vehicles/{id}/connections]

Allows a user to retrieve a collection of electric vehicle - electric vehicle supply equipment (EVSE) connections associated with an electric vehicle. A valid {id} can be obtained by calling the /{version}/{trial}/vehicles/{id} service. 'Ireland' is the only trial offering this service.

Parameters

Name	Type	Example	Description
version	String	v0.1	The version of the API to use.
trial	String	Ireland	The trial infrastructure to use for getting the EVSE connections

The class diagram of the response (instance of ConnectionsReport) follows in Figure 23.

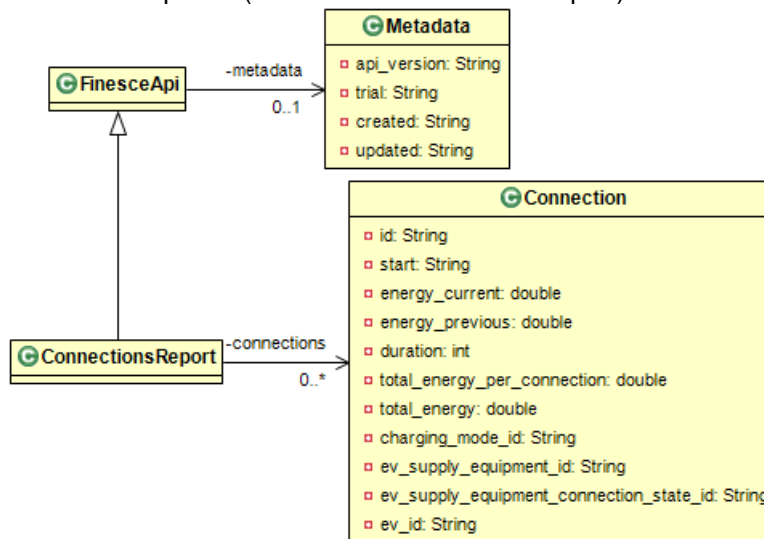

Figure 23: Class diagram of a ConnectionsReport response.

The attributes of the relevant response class are detailed next.

Table 38: Attributes of the ConnectionsReport class.

Name	Type	Description
metadata	Metadata	The metadata of the report (see Table 5, page 15)
connections	List<Connection>	The list of connections of interest (see Table 39, page 84)

Table 39: Attributes of the Connection class.

Name	Type	Description
id	String	The id of the connection
start	String	The time when the connection

		state changed, in an ISO8601 compliant format
energy_current	Double	Power being consumed by the connection in this minute
energy_previous	Double	Power being consumed by the connection in the previous minute
duration	Integer	Duration of the connection (seconds)
total_energy_per_connection	Double	The total power demand of this connection
total_energy	Double	The total power demand of all connections by this electric vehicle supply equipment
charging_mode_id	String	The id of the associated charging mode (see Table 43, page 90)
ev_supply_equipment_id	String	The id of the associated charging mode (see Table 45, page 93)
ev_supply_equipment_connection_state_id	String	The id of the related connection state (see Table 47, page 100)
ev_id	String	The id of the electric vehicle associated with this connection (see Figure 22, page 76)

2.7.8.1 Retrieve the available EV-EVSE connections of an electric vehicle [GET]

Request

- Headers
 1. x-auth-token: `an_auth_token`
 2. Accept: `application/json`

Response 200 (application/json)

- Body
 1. {
 2. "metadata":{
 3. "api_version":"0.1",
 4. "trial":"Ireland",
 5. "created":"2015-02-10T20:26:55+02:00",
 6. "updated":"2015-02-10T20:26:55+02:00"
 7. },
 8. "connections":[
 9. {
 10. "id":"1",
 11. "start":"2014-09-18T05:13:00.000Z",
 12. "energy_current":0.51,
 13. "energy_previous":0.52,
 14. "duration":3600,
 15. "total_energy_per_connection":2.2,
 16. "total_energy":9663.562,
 17. "charging_mode_id":"1",
 18. "ev_supply_equipment_id":"1",
 19. "ev_supply_equipment_connection_state_id":"1",
 20. "ev_id":"1"
 21. },
 22. {
 23. "id":"2",
 24. "start":"2014-09-18T06:13:00.000Z",
 25. "energy_current":0.49,

```

26.         "energy_previous":0.51,
27.         "duration":3600,
28.         "total_energy_per_connection":2.2,
29.         "total_energy":9663.762,
30.         "charging_mode_id":"1",
31.         "ev_supply_equipment_id":"1",
32.         "ev_supply_equipment_connection_state_id":"1",
33.         "ev_id":"1"
34.     }
35. ]
36. }
    
```

2.7.9 Get the supported electric vehicle types

Endpoint URL: [/{version}/{trial}/vehicle_types]

Provides information regarding the types of the electric vehicles of the trial. 'Ireland' is the only trial offering this service.

Parameters

Name	Type	Example	Description
version	String	v0.1	The version of the API to use.
trial	String	Ireland	The trial infrastructure to use for getting the EVSE charging modes.

The class diagram of the report (instance of VehicleTypesReport) follows in Figure 24.

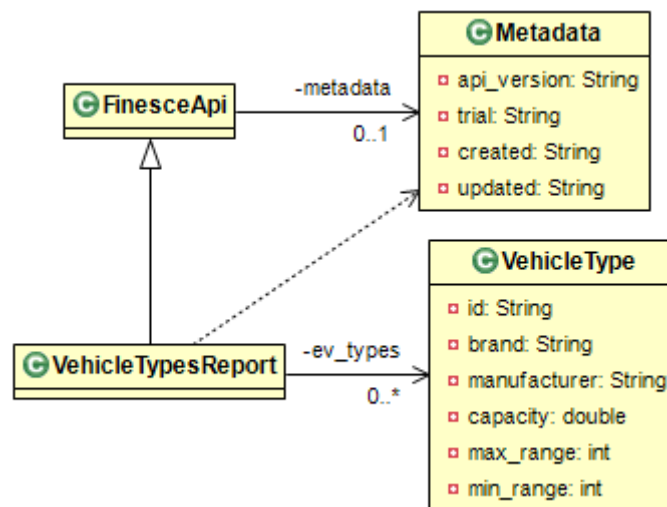

Figure 24: Class diagram of the VehicleTypesReport class

The attributes of the relevant class response are detailed in the following tables.

Table 40: Attributes of the VehicleTypesReport class

Name	Type	Description
metadata	Metadata	The metadata of the report (see Table 5, page 15)
ev_types	List<VehicleType>	The list of vehicle types supported by the trial (see Table 41, page 87)

Table 41: Attributes of the VehicleType class

Name	Type	Description
id	String	The id of the vehicle type
brand	String	The brand name of the vehicles of this type
manufacturer	String	The manufacturer of this vehicle type
capacity	Double	The capacity of the vehicle battery in kWh
max_range	Integer	The maximum range of the vehicle type in km
min_range	Integer	The minimum range of the vehicle type in km

2.7.9.1 Retrieve the available EV types [GET]

Request

- Headers
 1. x-auth-token: `an_auth_token`
 2. Accept: `application/json`

Response 200 (application/json)

- Body
 1. {
 2. "metadata":{
 3. "api_version":"0.1",
 4. "trial":"Ireland",
 5. "created":"2015-01-13T15:28:17+02:00",
 6. "updated":"2015-01-13T15:28:17+02:00"
 7. },
 8. "ev_types":[
 9. {
 10. "id":"1",
 11. "brand":"Leaf",
 12. "manufacturer":"Nissan",
 13. "capacity":24,
 14. "max_range":120,
 15. "min_range":160
 16. }
 17.]
 18. }

2.7.10 Get a specific electric vehicle type description, based on its id

Endpoint URL: `/{version}/{trial}/vehicle_types/{id}`

Allows a user to retrieve an electric vehicle type, based on its id. A valid {id} can be obtained by calling the `/{version}/{trial}/vehicle_types` service. 'Ireland' is the only trial offering this service.

Parameters

Name	Type	Example	Description
<i>version</i>	String	v0.1	The version of the API to use.
<i>trial</i>	String	Ireland	The trial infrastructure to use for getting the supported vehicle types.
<i>id</i>	String	1	The id of the electric vehicle type of interest.

The class diagram of the response (instance of VehicleTypesReport) has been already documented in Figure 24, page 86.

2.7.10.1 Retrieve an EV type description [GET]**Request**

- Headers
 1. x-auth-token: `an_auth_token`
 2. Accept: `application/json`

Response 200 (application/json)

- Body
 1. {
 2. "metadata":{
 3. "api_version":"0.1",
 4. "trial":"Ireland",
 5. "created":"2015-01-13T15:28:17+02:00",
 6. "updated":"2015-01-13T15:28:17+02:00"
 7. },
 8. "ev_types":[
 9. {
 10. "id":"1",
 11. "brand":"Leaf",
 12. "manufacturer":"Nissan",
 13. "capacity":24,
 14. "max_range":120,
 15. "min_range":160
 16. }
 17.]
 18. }

2.7.11 Get the electric vehicles sharing a common type, based on its id

Endpoint URL: `/{version}/{trial}/vehicle_types/{id}/vehicles`

Allows a user to retrieve a collection of electric vehicles associated with an electric vehicle type. A valid {id} can be obtained by calling the `/{version}/{trial}/vehicle_types` service. 'Ireland' is the only trial offering this service.

Parameters

Name	Type	Example	Description
<i>version</i>	String	v0.1	The version of the API to use.
<i>trial</i>	String	Ireland	The trial infrastructure to use for getting the EVSE charging modes.
<i>id</i>	String	1	The id of the electric vehicle type of interest.

The class type of the response (instance of VehiclesReport) has been already presented in Figure 22, page 76.

2.7.11.1 Retrieve the electric vehicles sharing a common type [GET]**Request**

- Headers
 1. x-auth-token: `an_auth_token`
 2. Accept: `application/json`

Response 200 (application/json)

- Body
 1. {
 2. "metadata":{
 3. "api_version":"0.1",
 4. "trial":"Ireland",
 5. "created":"2015-01-13T15:37:40+02:00",
 6. "updated":"2015-01-13T15:37:40+02:00"
 7. },
 8. "vehicles":[
 9. {
 10. "id":"1",
 11. "type":"1",
 12. "measurement_point":[
 13.],
 14.],
 15. "related_entity":[
 16.]
 17. }
 18. }
 19.]
 20. }

2.7.12 Get the EVs charging modes

Endpoint URL: `[/{version}/{trial}/charging_modes]`

Provides information regarding the charging modes of the electric vehicle supply equipment (EVSE) of the electric vehicles of the trial. 'Ireland' is the only trial offering this service.

Parameters

Name	Type	Example	Description
version	String	v0.1	The version of the API to use.
trial	String	Ireland	The trial infrastructure to use for getting the EVSE charging modes.

The class diagram of the response (instance of ChargingModesReport) is given in the next figure.

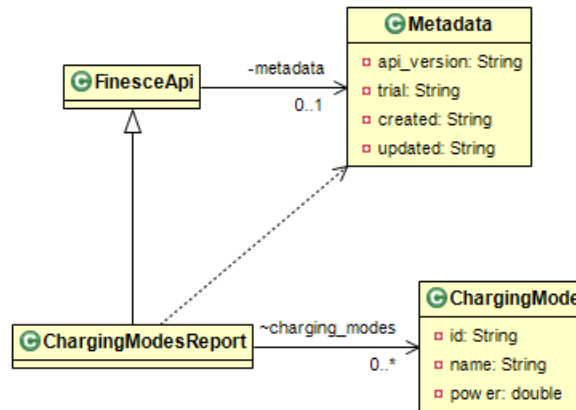

Figure 25: Class diagram of a ChargingModesReport response

The attributes of the respective response are detailed in the following tables.

Table 42: Attributes of the ChargingModesReport class

Name	Type	Description
metadata	Metadata	The metadata of the report (see Table 5, page 15)
charging_modes	List<ChargingMode>	The list of charging modes supported by the trial (see Table 43, page 90)

Table 43: Attributes of the ChargingMode class

Name	Type	Description
id	String	The id of the charging mode
name	String	The name of the charging mode
power	Double	The power dissipation of the charging mode in kW

2.7.12.1 Retrieve the available EVSE charging modes [GET]

Request

- Headers
 1. x-auth-token: `an_auth_token`
 2. Accept: `application/json`

Response 200 (application/json)

- Body

```

1. {
2.   "metadata":{
3.     "api_version":"0.1",
4.     "trial":"Ireland",
5.     "created":"2015-01-12T16:22:09+01:00",
6.     "updated":"2015-01-12T16:22:09+01:00"
7.   },
8.   "charging_modes":[
9.     {
10.      "id":"1",
11.      "name":"Single Phase 16A",
12.      "power":1.07
13.    },
14.    {
15.      "id":"2",
16.      "name":"Single Phase 8A",
17.      "power":3.05
18.    }
19.  ]
20. }

```

2.7.13 Get a charging mode based on an id

Endpoint URL: `/{version}/{trial}/charging_modes/{id}`

Allows a user to retrieve a chargingmode based on an id. A valid {id} can be obtained by calling the `/{version}/{trial}/charging_modes` service. 'Ireland' is the only trial offering this service.

Parameters

Name	Type	Example	Description
<i>version</i>	String	v0.1	The version of the API to use.
<i>trial</i>	String	Ireland	The trial infrastructure to use for getting the EVSE charging modes.
<i>id</i>	String	1	The id of the charging_mode to get information for.

The class diagram of the response (instance of ChargingModesReport) has been already given in Figure 25, page 90.

2.7.13.1 Retrieve a charging mode based on an id [GET]

Request

- Headers
 1. x-auth-token: `an_auth_token`
 2. Accept: `application/json`

Response 200 (application/json)

- Body
 1. {
 2. "metadata":{

```

3.     "api_version":"0.1",
4.     "trial":"Ireland",
5.     "created":"2015-01-12T16:25:32+01:00",
6.     "updated":"2015-01-12T16:25:32+01:00"
7.   },
8.   "charging_modes":[
9.     {
10.      "id":"1",
11.      "name":"Single Phase 16A",
12.      "power":1.07
13.    }
14.  ]
15. }
    
```

2.7.14 Get the electric vehicle supply equipment components related to a charging mode

Endpoint URL: `[/{version}/{trial}/charging_modes/{id}/evses]`

Allows a user to retrieve a collection of electric vehicle supply equipment components (EVSEs) associated with a charging mode. A valid {id} can be obtained by calling the `[/{version}/{trial}/charging_modes]` service. 'Ireland' is the only trial offering this service.

Parameters

Name	Type	Example	Description
<i>version</i>	String	v0.1	The version of the API to use.
<i>trial</i>	String	Ireland	The trial infrastructure to use for calling the service
<i>id</i>	String	1	The id of the charging_mode to get information for.

The class diagram of the response (instance of VehicleSupplyEquipmentReport) is given in the next figure.

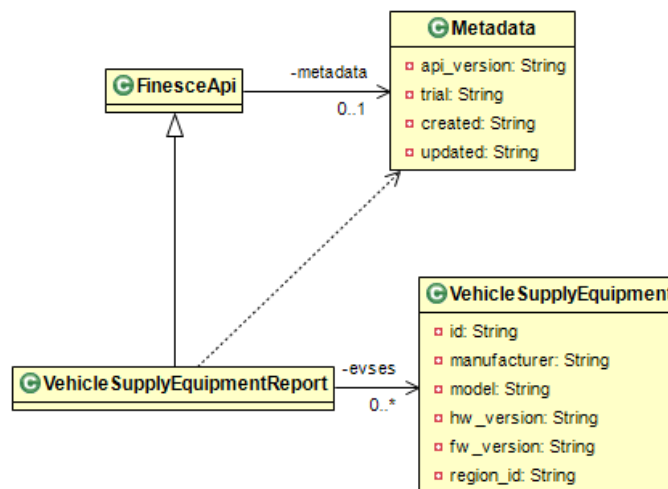

Figure 26: Class diagram of a VehicleSupplyEquipmentReport response.

The attributes of the relevant response are detailed in the tables following.

Table 44: Attributes of the VehicleSupplyEquipmentReport class

Name	Type	Description
metadata	Metadata	The metadata of the report (see Table 5, page 15)
evses	List<VehicleSupplyEquipment>	The list of EVSEs supported by the trial (see Table 45, page 93)

Table 45: Attributes of the VehicleSupplyEquipment class

Name	Type	Description
id	String	The id of the EVSE
manufacturer	String	The manufacturer of the EVSE
model	String	The model of the EVSE
hw_version	String	The hardware version of the EVSE
fw_version	String	The software version of the EVSE
region_id	String	The id of the region associated with this EVSE (see Table 64, page 133)

2.7.14.1 Retrieve the EVSEs related to a charging mode [GET]

Request

- Headers
 1. x-auth-token: `an_auth_token`
 2. Accept: `application/json`

Response 200 (application/json)

- Body
 1. {
 2. "metadata":{
 3. "api_version":"0.1",
 4. "trial":"Ireland",
 5. "created":"2015-01-12T16:31:53+01:00",
 6. "updated":"2015-01-12T16:31:53+01:00"
 7. },
 8. "evses ":[
 9. {
 10. "id":"1",
 11. "manufacturer":"M2C",
 12. "model":"M2C",
 13. "hw_version":"1.0",
 14. "fw_version":"1.0",
 15. "region_id":"1"
 16. },
 17. {
 18. "id":"2",
 19. "manufacturer":"M2C",
 20. "model":"M2C",
 21. "hw_version":"1.0",
 22. "fw_version":"1.0",
 23. "region_id":"1"
 24. }
 25.]
 26. }

2.7.15 Get the EV types related to a charging mode

Endpoint URL: `[/{version}/{trial}/charging_modes/{id}/evtypes]`

Allows a user to retrieve a collection of electric vehicle types associated with a charging mode. A valid {id} can be obtained by calling the `[/{version}/{trial}/charging_modes]` service. 'Ireland' is the only trial offering this service.

Parameters

Name	Type	Example	Description
<code>version</code>	String	v0.1	The version of the API to use.
<code>trial</code>	String	Ireland	The trial infrastructure to use for calling the service
<code>id</code>	String	1	The id of the charging_mode for which to get the electric vehicle types.

The class diagram of the response has been already given in Figure 24, page 86.

2.7.15.1 Retrieve the EV types related to a charging mode [GET]

Request

- Headers
 1. x-auth-token: `an_auth_token`
 2. Accept: `application/json`

Response 200 (application/json)

- Body
 1. {
 2. "metadata":{
 3. "api_version":"0.1",
 4. "trial":"Ireland",
 5. "created":"2015-01-12T17:17:17+01:00",
 6. "updated":"2015-01-12T17:17:17+01:00"
 7. },
 8. "ev_types":[
 9. {
 10. "id":"1",
 11. "brand":"Leaf",
 12. "manufacturer":"Nissan",
 13. "capacity":24,
 14. "max_range":120,
 15. "min_range":160
 16. }
 17.]
 18. }

2.7.16 Get the electric vehicle charging states

Endpoint URL: `[/{version}/{trial}/charging_states]`

Provides information regarding the charging states of the electric vehicle supply equipment (EVSE) of the electric vehicles of the trial. 'Ireland' is the only trial offering this service.

Parameters

Name	Type	Example	Description
<i>version</i>	String	v0.1	The version of the API to use.
<i>trial</i>	String	Ireland	The trial infrastructure to use for getting the EVSE charging states.

The class diagram of the response (instance of ChargingStatesReport) has been already given in Figure 20, page 59.

2.7.16.1 Retrieve the available EVSE charging states [GET]**Request**

- Headers
 1. x-auth-token: `an_auth_token`
 2. Accept: `application/json`

Response 200 (application/json)

- Body
 1. {
 2. "metadata":{
 3. "api_version":"0.1",
 4. "trial":"Ireland",
 5. "created":"2015-01-12T17:39:53+01:00",
 6. "updated":"2015-01-12T17:39:53+01:00"
 7. },
 8. "charging_states":[
 9. {
 10. "id":"1",
 11. "change_requested":false,
 12. "responded":false,
 13. "requested_state_is_on":false,
 14. "is_charging":false,
 15. "is_connected":false,
 16. "battery_full":false,
 17. "ev_id":"1",
 18. "ev_supply_equipment_id":"1",
 19. "timeslot_id":"1",
 20. "charging_mode_id":"1"
 21. },
 22. {
 23. "id":"2",
 24. "change_requested":false,
 25. "responded":false,
 26. "requested_state_is_on":false,
 27. "is_charging":false,
 28. "is_connected":false,
 29. "battery_full":false,
 30. "ev_id":"1",
 31. "ev_supply_equipment_id":"1",
 32. "timeslot_id":"2",
 33. "charging_mode_id":"1"
 34. }

```

35.   ]
36. }

```

2.7.17 Get an EV charging state based on its id

Endpoint URL: `[/{version}/{trial}/charging_states/{id}]`

Allows a user to retrieve a charging state based on an id. A valid {id} can be obtained by calling the `[/{version}/{trial}/charging_states` service. 'Ireland' is the only trial offering this service.

Parameters

Name	Type	Example	Description
<code>version</code>	String	v0.1	The version of the API to use.
<code>trial</code>	String	Ireland	The trial infrastructure to use for getting the EVSE charging modes.
<code>id</code>	String	1	The id of the charging state to get information for.

The class diagram of the response (instance of `ChargingStatesReport`) has been already given in Figure 20, page 59.

2.7.17.1 Retrieve a charging state based on an id [GET]

Request

- Headers
 1. `x-auth-token`: `an_auth_token`
 2. `Accept`: `application/json`

Response 200 (application/json)

- Body
 1. {
 2. "metadata":{
 3. "api_version":"0.1",
 4. "trial":"Ireland",
 5. "created":"2015-01-12T17:41:14+01:00",
 6. "updated":"2015-01-12T17:41:14+01:00"
 7. },
 8. "charging_states":[
 9. {
 10. "id":"1",
 11. "change_requested":false,
 12. "responded":false,
 13. "requested_state_is_on":false,
 14. "is_charging":false,
 15. "is_connected":false,
 16. "battery_full":false,
 17. "ev_id":"1",
 18. "ev_supply_equipment_id":"1",
 19. "timeslot_id":"1",
 20. "charging_mode_id":"1"
 21. }

```

22.     ]
23. }

```

2.7.18 Get the available EVSE connections

Endpoint URL: `[/{version}/{trial}/connections]`

Allows a user to retrieve a collection of the available EVSE connections. 'Ireland' is the only trial offering this service.

Parameters

Name	Type	Example	Description
<i>version</i>	String	v0.1	The version of the API to use.
<i>trial</i>	String	Ireland	The trial infrastructure to use for getting the EV-EVSE connections.

The class diagram of the response (instance of ConnectionsReport) has been already given in Figure 23, page 84.

2.7.18.1 Retrieve the available EVSE connections [GET]

Request

- Headers
 1. x-auth-token: `an_auth_token`
 2. Accept: `application/json`

Response 200 (application/json)

- Body
 1. {
 2. "metadata":{
 3. "api_version":"0.1",
 4. "trial":"Ireland",
 5. "created":"2015-01-12T17:50:21+01:00",
 6. "updated":"2015-01-12T17:50:21+01:00"
 7. },
 8. "connections":[
 9. {
 10. "id":"1",
 11. "start":"2014-09-18T05:13:00.000Z",
 12. "energy_current":0.51,
 13. "energy_previous":0.52,
 14. "duration":3600,
 15. "total_energy_per_connection":2.2,
 16. "total_energy":9663.562,
 17. "charging_mode_id":"1",
 18. "ev_supply_equipment_id":"1",
 19. "ev_supply_equipment_connection_state_id":"1",
 20. "ev_id":"1"
 21. },
 22. {
 23. "id":"2",
 24. "start":"2014-09-18T06:13:00.000Z",

```

25.         "energy_current":0.49,
26.         "energy_previous":0.51,
27.         "duration":3600,
28.         "total_energy_per_connection":2.2,
29.         "total_energy":9663.762,
30.         "charging_mode_id":"1",
31.         "ev_supply_equipment_id":"1",
32.         "ev_supply_equipment_connection_state_id":"1",
33.         "ev_id":"1"
34.     }
35. ]
36. }

```

2.7.19 Get an EVSE connection based on its id

Endpoint URL: `/{version}/{trial}/connections/{id}`

Allows a user to retrieve an EV-EVSE connection, based on its id. A valid {id} can be obtained by calling the `/{version}/{trial}/connections` service. 'Ireland' is the only trial offering this service.

Parameters

Name	Type	Example	Description
<i>version</i>	String	v0.1	The version of the API to use.
<i>trial</i>	String	Ireland	The trial infrastructure to use for getting the desired EV-EVSE connection
<i>id</i>	String	1	The id of the connection to get information for.

The class diagram of the response (instance of `ConnectionsReport`) has been already given in Figure 23, page 84.

2.7.19.1 Retrieve an EVSE connection based on an id [GET]

Request

- Headers
 1. x-auth-token: `an_auth_token`
 2. Accept: `application/json`

Response 200 (application/json)

- Body
 1. {
 2. "metadata":{
 3. "api_version":"0.1",
 4. "trial":"Ireland",
 5. "created":"2015-01-12T17:49:54+01:00",
 6. "updated":"2015-01-12T17:49:54+01:00"
 7. },
 8. "connections":[
 9. {
 10. "id":"1",
 11. "start":"2014-09-18T05:13:00.000Z",
 12. "energy_current":0.51,
 13. "energy_previous":0.52,

```

14.         "duration":3600,
15.         "total_energy_per_connection":2.2,
16.         "total_energy":9663.562,
17.         "charging_mode_id":"1",
18.         "ev_supply_equipment_id":"1",
19.         "ev_supply_equipment_connection_state_id":"1",
20.         "ev_id":"1"
21.     }
22. ]
23. }

```

2.7.20 Get an EVSE charging mode based on a connection id

Endpoint URL: `[/{version}/{trial}/connections/{id}/charging_mode]`

Allows a user to retrieve a charging mode associated with an EVSE connection. A valid {id} can be obtained by calling the `/api/{version}/{trial}/connections` service. 'Ireland' is the only trial offering this service.

Parameters

Name	Type	Example	Description
<i>version</i>	String	v0.1	The version of the API to use.
<i>trial</i>	String	Ireland	The trial infrastructure to use for getting the EVSE charging modes.
<i>id</i>	String	1	The id of the connection to get information for.

The class diagram of the response (instance of ChargingModesReport) has been already given in Figure 25, page 90.

2.7.20.1 Retrieve the charging mode of an EVSE connection based on an id [GET]

Request

- Headers
 1. x-auth-token: `an_auth_token`
 2. Accept: `application/json`

Response 200 (application/json)

- Body
 1. {
 2. "metadata":{
 3. "api_version":"0.1",
 4. "trial":"Ireland",
 5. "created":"2015-01-12T17:53:22+01:00",
 6. "updated":"2015-01-12T17:53:22+01:00"
 7. },
 8. "charging_modes":[
 9. {
 10. "id":"1",
 11. "name":"Single Phase 16A",
 12. "power":1.07

```

13.     }
14.   ]
15. }
    
```

2.7.21 Get an EVSE connection state based on a connection id

Endpoint URL: `[/version]/{trial}/connections/{id}/connection_state`

Allows a user to retrieve an EVSE connection state associated with an EV-EVSE connection. A valid {id} can be obtained by calling the `/version/{trial}/connections` service. 'Ireland' is the only trial offering this service.

Parameters

Name	Type	Example	Description
<i>version</i>	String	v0.1	The version of the API to use.
<i>trial</i>	String	Ireland	The trial infrastructure to use for getting the required EVSE connection state.
<i>id</i>	String	1	The id of the connection to get information for.

The class diagram of the response (instance of ConnectionStatesReport) is given in Figure 27.

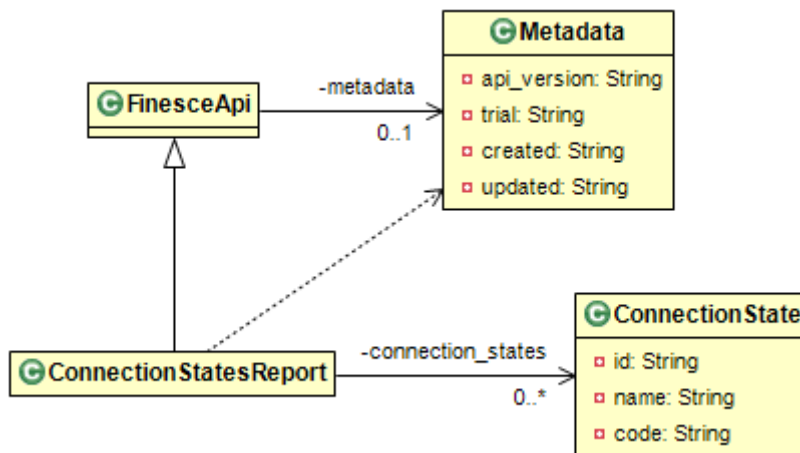

Figure 27: Class diagram of a ConnectionStatesReport response.

The attributes of the relevant response class follow:

Table 46: Attributes of the ConnectionStatesReport class

Name	Type	Description
metadata	Metadata	The metadata of the report (see Table 5, page 15)
connection_states	List<ConnectionState>	The list of connection states (see Table 47, page 100)

Table 47: Attributes of the ConnectionState class

Name	Type	Description
id	String	The id of the connection state
name	String	The name of the connection state
code	String	The code of the connection state

2.7.21.1 Retrieve a connection state based on a connection id [GET]

Request

- Headers
 1. x-auth-token: `an_auth_token`
 2. Accept: `application/json`

Response 200 (application/json)

- Body
 1. {
 2. "metadata":{
 3. "api_version":"0.1",
 4. "trial":"Ireland",
 5. "created":"2015-01-12T17:55:30+01:00",
 6. "updated":"2015-01-12T17:55:30+01:00"
 7. },
 8. "connection_states":[
 9. {
 10. "id":"1",
 11. "name":"is_connected",
 12. "code":"2"
 13. }
 14.]
 15. }

2.7.22 Get the available EVSEs connection states

Endpoint URL: `[/]{version}/{trial}/connection_states`

Allows a user to retrieve a collection of EV-EVSE connection states. 'Ireland' is the only trial offering this service.

Parameters

Name	Type	Example	Description
<code>version</code>	String	v0.1	The version of the API to use.
<code>trial</code>	String	Ireland	The trial infrastructure to use for getting the available EV-EVSE connection states

The class diagram of the response (instance of `ConnectionStatesReport`) has been already given in Figure 27, page 100.

2.7.22.1 Retrieve the available EVSE connection states [GET]

Request

- Headers
 1. x-auth-token: `an_auth_token`
 2. Accept: `application/json`

Response 200 (application/json)

- Body
 1. {
 2. "metadata":{
 3. "api_version":"0.1",
 4. "trial":"Ireland",
 5. "created":"2015-01-12T17:43:23+01:00",
 6. "updated":"2015-01-12T17:43:23+01:00"
 7. },
 8. "connection_states":[
 9. {
 10. "id":"1",
 11. "name":"is_connected",
 12. "code":"2"
 13. },
 14. {
 15. "id":"2",
 16. "name":"not_connected",
 17. "code":"3"
 18. }
 19.]
 20. }

2.7.23 Get an EVSE connection state through its id

Endpoint URL: `/{version}/{trial}/connection_states/{id}`

Allows a user to retrieve an EVSE connection state record, based on its id. A valid {id} can be obtained by calling the `/{version}/{trial}/connection_states` service. 'Ireland' is the only trial offering this service.

Parameters

Name	Type	Example	Description
<i>version</i>	String	v0.1	The version of the API to use.
<i>trial</i>	String	Ireland	The trial infrastructure to use for getting the available EV-EVSE connection states
<i>id</i>	String	1	The id of the connection state to get information for.

The class diagram of the response (instance of ConnectionStatesReport) has been already given in Figure 27, page 100.

2.7.23.1 Retrieve a connection state based on an id [GET]

Request

- Headers
 1. x-auth-token: `an_auth_token`
 2. Accept: `application/json`

Response 200 (application/json)

- Body
 1. {
 2. "metadata":{

```

3.     "api_version": "0.1",
4.     "trial": "Ireland",
5.     "created": "2015-01-12T17:45:15+01:00",
6.     "updated": "2015-01-12T17:45:15+01:00"
7.   },
8.   "connection_states": [
9.     {
10.      "id": "1",
11.      "name": "is_connected",
12.      "code": "2"
13.    }
14.  ]
15. }

```

2.7.24 Get all the electric vehicle supply equipment components available

Endpoint URL: `[/{version}/{trial}/supply_equipment]`

Allows a user to retrieve a collection of electric vehicle supply equipment (EVSE) components. 'Ireland' is the only trial offering this service.

Parameters

Name	Type	Example	Description
<i>version</i>	String	v0.1	The version of the API to use.
<i>trial</i>	String	Ireland	The trial infrastructure to use for getting the available EVSEs

The class diagram of the response (instance of `VehicleSupplyEquipmentReport`) has been already given in Figure 26, page 92.

2.7.24.1 Retrieve the set of available EVSE components [GET]

Request

- Headers
 1. x-auth-token: `an_auth_token`
 2. Accept: `application/json`

Response 200 (application/json)

- Body
 1. {
 2. "metadata": {
 3. "api_version": "0.1",
 4. "trial": "Ireland",
 5. "created": "2015-01-13T14:21:34+02:00",
 6. "updated": "2015-01-13T14:21:34+02:00"
 7. },
 8. "evses": [
 9. {
 10. "id": "1",
 11. "manufacturer": "M2C",
 12. "model": "M2C",
 13. "hw_version": "1.0",
 14. "fw_version": "1.0",

```

15.         "region_id": "1"
16.     },
17.     {
18.         "id": "2",
19.         "manufacturer": "M2C",
20.         "model": "M2C",
21.         "hw_version": "1.0",
22.         "fw_version": "1.0",
23.         "region_id": "1"
24.     }
25. ]
26. }

```

2.7.25 Get an electric vehicle supply equipment component, based on its id

Endpoint URL: `/{version}/{trial}/supply_equipment/{id}`

Allows a user to retrieve an electric vehicle supply equipment component (EVSE), based on its id. A valid {id} can be obtained by calling the `/{version}/{trial}/supply_equipment/` service. 'Ireland' is the only trial offering this service.

Parameters

Name	Type	Example	Description
<i>version</i>	String	v0.1	The version of the API to use.
<i>trial</i>	String	Ireland	The trial infrastructure to use for getting the EVSE component of interest
<i>id</i>	String	1	The id of the EVSE to get information for.

The class diagram of the response (instance of `VehicleSupplyEquipmentReport`) has been already given in Figure 26, page 92.

2.7.25.1 Retrieve an electric vehicle supply equipment component [GET]

Request

- Headers
 1. x-auth-token: `an_auth_token`
 2. Accept: `application/json`

Response 200 (application/json)

- Body
 1. {
 2. "metadata":{
 3. "api_version": "0.1",
 4. "trial": "Ireland",
 5. "created": "2015-01-13T14:25:22+02:00",
 6. "updated": "2015-01-13T14:25:22+02:00"
 7. },
 8. "evses": [
 9. {
 10. "id": "1",
 11. "manufacturer": "M2C",

```

12.         "model": "M2C",
13.         "hw_version": "1.0",
14.         "fw_version": "1.0",
15.         "region_id": "1"
16.     }
17. ]
18. }

```

2.7.26 Get the charging modes associated with an electric vehicle supply equipment component, based on its id

Endpoint URL: `[/{version}/{trial}/supply_equipment/{id}/charging_modes]`

Allows a user to retrieve a collection of charging modes associated with an electric vehicle supply equipment component (EVSE), based on its id. A valid {id} can be obtained by calling the `[/{version}/{trial}/supply_equipment/` service. 'Ireland' is the only trial offering this service.

Parameters

Name	Type	Example	Description
<i>version</i>	String	v0.1	The version of the API to use.
<i>trial</i>	String	Ireland	The trial infrastructure to use for getting the EVSE charging modes.
<i>id</i>	String	1	The id of the EVSE to get information for.

The class diagram of the response (instance of ChargingModesReport) has been already given in Figure 25, page 90.

2.7.26.1 Retrieve an electric vehicle supply equipment component [GET]

Request

- Headers
 1. x-auth-token: `an_auth_token`
 2. Accept: `application/json`

Response 200 (application/json)

- Body
 1. {
 2. "metadata":{
 3. "api_version": "0.1",
 4. "trial": "Ireland",
 5. "created": "2015-01-13T14:29:06+02:00",
 6. "updated": "2015-01-13T14:29:06+02:00"
 7. },
 8. "charging_modes": [
 9. {
 10. "id": "1",
 11. "name": "Single Phase 16A",
 12. "power": 1.07
 13. },
 14.]

```

15.         "id":"2",
16.         "name":"Single Phase 8A",
17.         "power":3.05
18.     }
19. ]
20. }

```

2.7.27 Get the connections associated with an electric vehicle supply equipment component, based on its id

Endpoint URL: `[/{version}/{trial}/supply_equipment/{id}/connections]`

Allows a user to retrieve a collection of electric vehicle supply equipment (EVSE) connections associated with an EVSE, based on its id. A valid {id} can be obtained by calling the `[/{version}/{trial}/supply_equipment/` service. 'Ireland' is the only trial offering this service.

Parameters

Name	Type	Example	Description
<i>version</i>	String	v0.1	The version of the API to use.
<i>trial</i>	String	Ireland	The trial infrastructure to use for getting the EVSE charging modes.
<i>id</i>	String	1	The id of the EVSE to get information for.

The class diagram of the response (instance of ConnectionsReport) has been already given in Figure 23, page 84.

2.7.27.1 Retrieve an electric vehicle supply equipment component [GET]

Request

- Headers
 1. x-auth-token: `an_auth_token`
 2. Accept: `application/json`

Response 200 (application/json)

- Body
 1. {
 2. "metadata":{
 3. "api_version":"0.1",
 4. "trial":"Ireland",
 5. "created":"2015-01-13T14:31:29+02:00",
 6. "updated":"2015-01-13T14:31:29+02:00"
 7. },
 8. "connections":[
 9. {
 10. "id":"1",
 11. "start":"2014-09-18T05:13:00.000Z",
 12. "energy_current":0.51,
 13. "energy_previous":0.52,
 14. "duration":3600,
 15. "total_energy_per_connection":2.2,
 16. "total_energy":9663.562,
 17. "charging_mode_id":"1",

```
18.         "ev_supply_equipment_id":"1",
19.         "ev_supply_equipment_connection_state_id":"1",
20.         "ev_id":"1"
21.     },
22.     {
23.         "id":"2",
24.         "start":"2014-09-18T06:13:00.000Z",
25.         "energy_current":0.49,
26.         "energy_previous":0.51,
27.         "duration":3600,
28.         "total_energy_per_connection":2.2,
29.         "total_energy":9663.762,
30.         "charging_mode_id":"1",
31.         "ev_supply_equipment_id":"1",
32.         "ev_supply_equipment_connection_state_id":"1",
33.         "ev_id":"1"
34.     }
35. ]
36. }
```

2.8 External information

This API is responsible for handling requests/responses from services that do not directly map to energy-related data.

2.8.1 Get the latest known social events

Endpoint URL: [/{version}/{trial}/social]

This service is meant to offer a list of social events that can temporarily influence the electricity consumption.

Parameters

Name	Type	Example	Description
version	String	v0.1	The version of the API to use.
trial	String	Terni	The trial infrastructure to use for invoking the respective service.

The class diagram of the response (instance of SocialEventsReport) is provided in Figure 28.

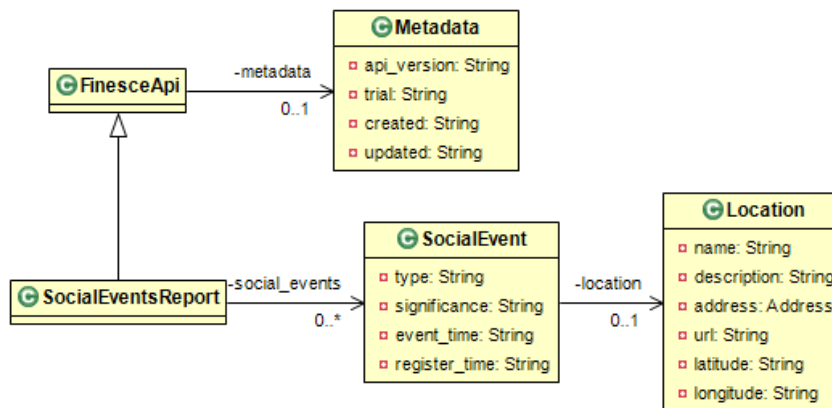

Figure 28: Class diagram of the SocialEventsReport class.

The attributes of the respective response are detailed in the following tables.

Table 48: Attributes of the SocialEventsReport class

Name	Type	Description
metadata	Metadata	The metadata of the report (see Table 5, page 15)
social_events	List<SocialEvent>	The list of known social events (see Table 49, page 108)

Table 49: Attributes of the SocialEvent class

Name	Type	Description
location	Location	The location of the event
type	String	The type of the event
significance	String	The significance of the event, in terms of influence to the smart grid load
event_time	String	The time of the event, in an ISO8601 compliant format
register_time	String	The registration time of the event, in an ISO8601 compliant format

Table 50: Attributes of the Location class

Name	Type	Description
name	String	The name of the location
description	String	A description of the location
address	String	The address of the location
url	String	The URL for the location (if any)
latitude	String	The latitude of the location
longitude	String	The longitude of the location

2.8.1.1 Retrieve the list of upcoming social events [GET]

Request

- Headers

1. x-auth-token: `an_auth_token`
2. Accept: `application/json`

Response 200 (application/json)

- Body

```

1. {
2.   "metadata":{
3.     "api_version":"0.1",
4.     "trial":"Terni",
5.     "created":"2015-01-21T17:46:35+02:00",
6.     "updated":"2015-01-21T17:46:35+02:00"
7.   },
8.   "event":[
9.     {
10.      "location":{
11.        "name":"Terni Stadium",
12.        "description":null,
13.        "address":{
14.          "street_name":"Via dello Stadio",
15.          "number":0,
16.          "city":null,
17.          "province":null,
18.          "zip_code":0,
19.          "country":null
20.        },
21.        "url":null,
22.        "latitude":"42.558922",
23.        "longitude":"12.63804"
24.      },
25.      "significance":"1",
26.      "event_time": "2014-11-30T20:30:00+02:00",
27.      "type":"Ternana - Cittadella",
28.      "register_time":"2014-11-17T17:24:39+02:00"
29.    },
30.    . . .
31.    {
32.      "location":{
33.        "name":"Central Market",
34.        "description":null,
35.        "address":{
36.          "street_name":"Piazza Giusti",

```

```

37.         "number":0,
38.         "city":null,
39.         "province":null,
40.         "zip_code":0,
41.         "country":null
42.     },
43.     "url":null,
44.     "latitude":"42.558922",
45.     "longitude":"12.63804"
46. },
47. "significance":"1",
48. "event_time":"2014-12-19T20:30:00+02:00",
49. "type":"Christmas Markets",
50. "register_time":"2014-11-12T15:50:26+02:00"
51. }
52. ]
53. }

```

2.8.2 Get a specific number of the latest known social events

Endpoint URL: `[/{version}/{trial}/social/{events_number}]`

This service is meant to offer a list containing a specific number of social events that can temporarily influence the electricity consumption.

Parameters

Name	Type	Example	Description
<i>version</i>	String	v0.1	The version of the API to use.
<i>trial</i>	String	Terni	The trial infrastructure to use for invoking the respective service.
<i>events_number</i>	Number	2	The number of known social events to fetch.

The class diagram of the response (instance of `SocialEventsReport`) has been already presented in Figure 28, page 108.

2.8.2.1 Retrieve a list of upcoming social events [GET]

Request

- Headers
 1. x-auth-token: `an_auth_token`
 2. Accept: `application/json`

Response 200 (application/json)

- Body
 1. {
 2. "metadata":{
 3. "api_version":"0.1",
 4. "trial":"Terni",
 5. "created":"2015-01-21T17:46:35+02:00",

```
6.     "updated": "2015-01-21T17:46:35+02:00"
7.   },
8.   "event": [
9.     {
10.      "location": {
11.        "name": "Central Market",
12.        "description": null,
13.        "address": {
14.          "street_name": "Piazza Giusti",
15.          "number": 0,
16.          "city": null,
17.          "province": null,
18.          "zip_code": 0,
19.          "country": null
20.        },
21.        "url": null,
22.        "latitude": "42.558922",
23.        "longitude": "12.63804"
24.      },
25.      "significance": "1",
26.      "event_time": "2014-12-20T20:30:00+02:00",
27.      "type": "Christmas Markets",
28.      "register_time": "2014-11-12T15:51:25+02:00"
29.    },
30.    {
31.      "location": {
32.        "name": "Central Market",
33.        "description": null,
34.        "address": {
35.          "street_name": "Piazza Giusti",
36.          "number": 0,
37.          "city": null,
38.          "province": null,
39.          "zip_code": 0,
40.          "country": null
41.        },
42.        "url": null,
43.        "latitude": "42.558922",
44.        "longitude": "12.63804"
45.      },
46.      "significance": "1",
47.      "event_time": "2014-12-19T20:30:00+02:00",
48.      "type": "Christmas Markets",
49.      "register_time": "2014-11-12T15:50:26+02:00"
50.    }
51.  ]
52. }
```

2.9 Metering infrastructure details

This set of APIs exposes services related to the presentation of the metering equipment of a Smart Energy site, be it a Smart Grid or a Smart Building.

2.9.1 Get the list of all meters

Endpoint URL: `[/{version}/{trial}/meters]`

Gets a list of the available meters along with the set of their accompanying information.

Parameters

Name	Type	Example	Description
<i>version</i>	String	v0.1	The version of the API to use.
<i>trial</i>	String	Terni	The trial infrastructure to use for invoking the respective service.

The class diagram of the response (instance of MetersReport) is given in Figure 29.

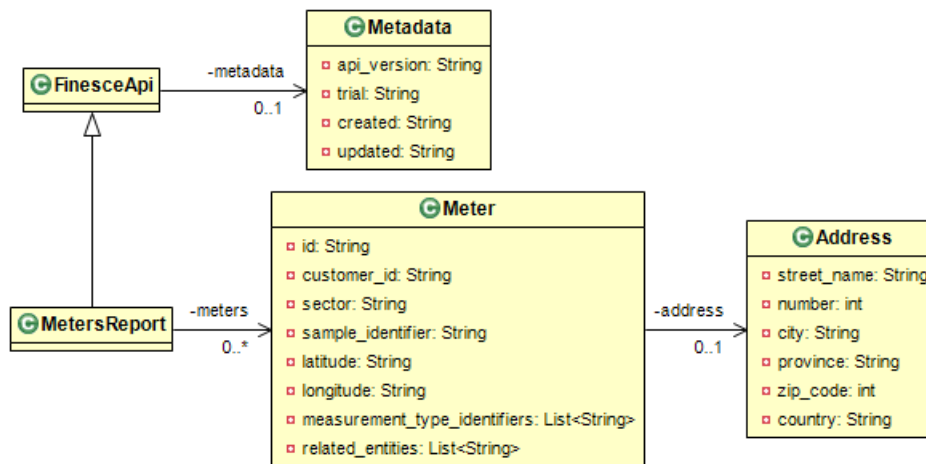

Figure 29: Class diagram of a MetersReport response.

The attributes of the response are detailed in the following tables.

Table 51: Attributes of the MetersReport class

Name	Type	Description
metadata	Metadata	The metadata of the report (see Table 5, page 15)
meters	List<Meter>	The list of trial meters (see Table 52, page 112)

Table 52: Attributes of the Meter class

Name	Type	Description
id	String	The id of the meter
address	Address	The address of the meter installation (see Table 10, page 21)
customer_id	String	The id of the customer associated with the meter
sector	String	The sector the meter (customer) belongs

		to
sample_identifier	String	An indicator of the metering frequency of the meter
latitude	String	The latitude of the meter installation point
longitude	String	The longitude of the meter installation point
measurement_type_identifiers	List<String>	A list of measurement types supported by the meter (see page 29 for details on supported types)
related_entities	List<String>	A list of entities related to the meter (e.g. a building)

2.9.1.1 Retrieve the list of available meters [GET]

Request

- Headers

1. x-auth-token: `an_auth_token`
2. Accept: `application/json`

Response 200 (application/json)

- Body

```

1. {
2.   "metadata":{
3.     "api_version":"0.1",
4.     "trial":"Terni",
5.     "created":"2015-01-22T11:41:53+02:00",
6.     "updated":"2015-01-22T11:41:53+02:00"
7.   },
8.   "meters":[
9.     {
10.      "id":"P2 AS E",
11.      "customer_id":"WP4_U_17",
12.      "sector":"LIGHTING",
13.      "address":null,
14.      "sample_identifier":null,
15.      "latitude":null,
16.      "longitude":null,
17.      "measurement_type_identifiers":[
18.        "EnergyConsumptionGrid",
19.        "EnergyProductionGrid",
20.        "PowerSupplyGrid",
21.        "PowerDemandGrid"
22.      ]
23.    },
24.    . . .
25.    {
26.      "id":"P2 AS E",
27.      "customer_id":"-",
28.      "sector":"SECONDARY_SUBSTATION",
29.      "address":null,
30.      "sample_identifier":null,
31.      "latitude":null,
32.      "longitude":null,
33.      "measurement_type_identifiers":[
34.        "EnergyConsumptionGrid",
35.        "EnergyProductionGrid",
36.        "PowerSupplyGrid",

```

```

37.         "PowerDemandGrid"
38.     ]
39. }
40. ]
41. }

```

2.9.2 Get a specific meter description

Endpoint URL: `[/]{version}/{trial}/meters/{search_type}:{search_value}`

Retrieves a meter based on a search string.

Parameters

Name	Type	Example	Description
<code>version</code>	String	v0.1	The version of the API to use.
<code>trial</code>	String	Terni	The trial infrastructure to use for invoking the respective service.
<code>search_type</code>	String	customer_id	The field of the meter to act as a search index.
<code>search_value</code>	String	WP4_U_3	The value of the field to search for.

The class diagram of the response (instance of MetersReport) is given in Figure 29, page 112.

2.9.2.1 Retrieve a meter based on a search string [GET]

Request

- Headers
 1. x-auth-token: `an_auth_token`
 2. Accept: `application/json`

Response 200 (application/json)

- Body
 1. {
 2. "metadata":{
 3. "api_version":"0.1",
 4. "trial":"Terni",
 5. "created":"2015-01-22T11:43:46+02:00",
 6. "updated":"2015-01-22T11:43:46+02:00"
 7. },
 8. "meters":[
 9. {
 10. "id":"P2 AS E",
 11. "customer_id":"WP4_U_3",
 12. "sector":"INDUSTRIAL",
 13. "address":null,
 14. "sample_identifier":null,
 15. "latitude":null,
 16. "longitude":null,
 17. "measurement_type_identifiers":[
 18. "EnergyConsumptionGrid",
 19. "EnergyProductionGrid",
 20. "PowerSupplyGrid",

```

21.         "PowerDemandGrid"
22.     ]
23. }
24. ]
25. }
    
```

2.9.3 Get the list of all available sectors

Endpoint URL: [/{version}/{trial}/meters/sectors]

Gets a list of the sectors that the meters may be deployed into.

Parameters

Name	Type	Example	Description
version	String	v0.1	The version of the API to use.
trial	String	Terni	The trial infrastructure to use for invoking the respective service.

The class type of the response (instance of SectorsReport) is given in Figure 30.

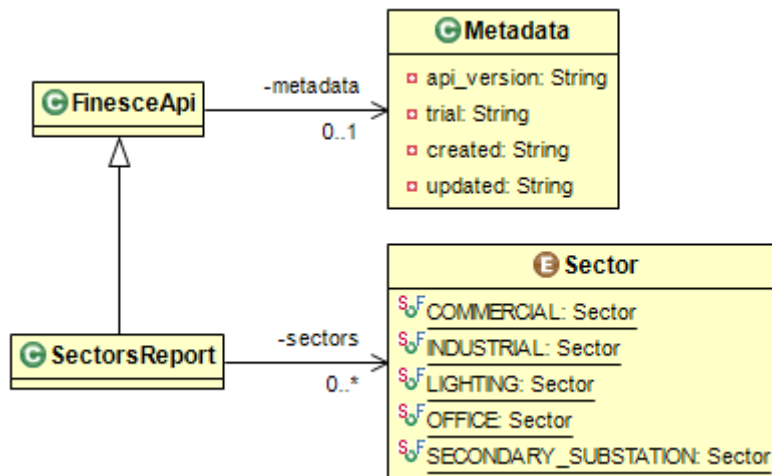

Figure 30: Class description of a SectorsReport response

The attributes of the relevant response are detailed below.

Table 53: Attributes of the SectorsReport class

Name	Type	Description
metadata	Metadata	The metadata of the report (see Table 5, page 15)
meters	List<Meter>	The list of trial meters (see Table 54, page 115)

Table 54: Attributes of the Sector enumeration

Name	Type	Description
Sector	Enumeration	The sector identifiers. Currently, COMMERCIAL, INDUSTRIAL, LIGHTING, OFFICE and SECONDARY_SUBSTATION are the only ones supported

2.9.3.1 Retrieve the list of available sectors [GET]

Request

- Headers
 1. x-auth-token: `an_auth_token`
 2. Accept: `application/json`

Response 200 (application/json)

- Body
 1. {
 2. "metadata":{
 3. "api_version":"0.1",
 4. "trial":"Terni",
 5. "created":"2015-01-22T11:44:34+02:00",
 6. "updated":"2015-01-22T11:44:34+02:00"
 7. },
 8. "sector":[
 9. "COMMERCIAL",
 10. "INDUSTRIAL",
 11. "LIGHTING",
 12. "OFFICE",
 13. "SECONDARY_SUBSTATION"
 14.]
 15. }

2.10 Optimization

This group of APIs offers access to supported optimization engines and their parametrization.

2.10.1 List available algorithm weights

Endpoint URL: `[/{version}/{trial}/algoweights]`

Allows a user to retrieve a collection of algoweights, as handled by the COS algorithm of the Irish FINESCE trial (WP5). 'Ireland' is the only trial offering this service.

Parameters

Name	Type	Example	Description
<i>version</i>	String	v0.1	The version of the API to use.
<i>trial</i>	String	Ireland	The trial infrastructure to use for invoking the respective service.

The class diagram of the response (instance of AlgoweightReport) has been already documented in Figure 19, page 58.

2.10.1.1 Retrieve a list of algorithm weights descriptions [GET]

Request

- Headers
 1. x-auth-token: `an_auth_token`
 2. Accept: `application/json`

Response 200 (application/json)

- Body
 1. {
 2. "metadata":{
 3. "api_version":"0.1",
 4. "trial":"Ireland",
 5. "created":"2015-01-07T15:58:33+01:00",
 6. "updated":"2015-01-07T15:58:33+01:00"
 7. },
 8. "algoweights":[
 9. {
 10. "id":"1",
 11. "renewables":"100.0",
 12. "interconnect":"0.0",
 13. "specific":"0.0",
 14. "timeslot_id":"1",
 15. "region_id":"1"
 16. },
 17. {
 18. "id":"2",
 19. "renewables":"100.0",
 20. "interconnect":"0.0",
 21. "specific":"0.0",
 22. "timeslot_id":"2",
 23. "region_id":"1"
 24. }
 25.]

26. }

2.10.2 Get an algorithm weight object based on its id

Endpoint URL: `[/{version}/{trial}/algoweights/{id}]`

Allows a user to retrieve an algoweights record, based on its ID. A valid {id} can be obtained by calling the /algoweights service. 'Ireland' is the only trial offering this service.

Parameters

Name	Type	Example	Description
<i>version</i>	String	v0.1	The version of the API to use.
<i>trial</i>	String	Ireland	The trial infrastructure to use for invoking the respective service.
<i>id</i>	String	1	The id of the algoweight object of interest.

The class diagram of the response (instance of AlgoweightReport) has been already documented in Figure 19, page 58.

2.10.2.1 Retrieve information regarding a single algorithm object [GET]

Request

- Headers
 1. x-auth-token: `an_auth_token`
 2. Accept: `application/json`

Response 200 (application/json)

- Body
 1. {
 2. "metadata":{
 3. "api_version":"0.1",
 4. "trial":"Ireland",
 5. "created":"2015-01-07T16:03:51+01:00",
 6. "updated":"2015-01-07T16:03:51+01:00"
 7. },
 8. "algoweights":[
 9. {
 10. "id":"1",
 11. "renewables":"100.0",
 12. "interconnect":"0.0",
 13. "specific":"0.0",
 14. "timeslot_id":"1",
 15. "region_id":"1"
 16. }
 17.]
 18. }

2.11 Pricing

This group of APIs provides information related to energy pricing at a regional level or customer level.

2.11.1 Get the available energy prices in a trial

Endpoint URL: `[/{version}/{trial}/prices]`

Allows a user to get information regarding the energy prices in the wider area of a trial. 'Malmo' is the only trial offering this service.

Parameters

Name	Type	Example	Description
<i>version</i>	String	v0.1	The version of the API to use.
<i>trial</i>	String	Malmo	The trial infrastructure to use for invoking the respective service.

The class diagram of the response (instance of PriceReport) is given in Figure 31.

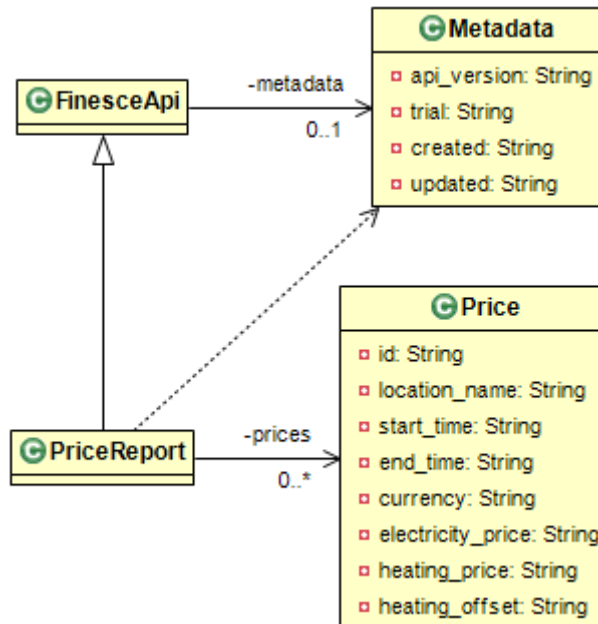

Figure 31: Class diagram of a PriceReport response.

The attributes of the relevant response are detailed in the tables below.

Table 55: Attributes of the PriceReport class

Name	Type	Description
metadata	Metadata	The metadata of the report (see Table 5, page 15)
prices	List<Price>	The prices of the trial (see Table 56, page 119)

Table 56: Attributes of the Price class

Name	Type	Description
id	String	The id of the price object
location_name	String	The name of the location/region the price refers to
start_time	String	The time from which on the price is valid, in an ISO8601 compliant format

end_time	String	The time until which on the price is valid, in an ISO8601 compliant format
currency	String	The currency of the prices listed
electricity_price	String	The price for electricity
heating_price	String	The price for heating energy
heating_offset	String	A parameter to calculate the heating energy price

2.11.1.1 Retrieve the available energy prices in a trial [GET]

Request

- Headers
 1. x-auth-token: `an_auth_token`
 2. Accept: `application/json`

Response 200 (application/json)

- Body
 1. {
 2. "metadata":{
 3. "api_version":"0.1",
 4. "trial":"Malmö",
 5. "created":"2015-01-13T16:05:15+02:00",
 6. "updated":"2015-01-13T16:05:15+02:00"
 7. },
 8. "prices":[
 9. {
 10. "id":"1",
 11. "location_name":"A",
 12. "start_time":"2015-01-13T15:05:15+02:00",
 13. "end_time":"2015-01-13T16:05:15+02:00",
 14. "currency":"Euro",
 15. "electricity_price":"10.7",
 16. "heating_price":"3.6",
 17. "heating_offset":"1"
 18. },
 19. {
 20. "id":"2",
 21. "location_name":"B",
 22. "start_time":"2015-01-13T15:05:15+02:00",
 23. "end_time":"2015-01-13T16:05:15+02:00",
 24. "currency":"Euro",
 25. "electricity_price":"10.7",
 26. "heating_price":"3.6",
 27. "heating_offset":"1"
 28. }
 29.]
 30. }

2.11.2 Get the available energy prices in a trial within a time range

Endpoint URL: `/{version}/{trial}/prices/{from}/{to}`

Allows a user to get information regarding the energy prices regardless of location. Valid {from} and {to} values are expressed in ISO8601 format. 'Malmö' is the only trial offering this service.

Parameters

Name	Type	Example	Description
<i>version</i>	String	v0.1	The version of the API to use.
<i>trial</i>	String	Malmo	The trial infrastructure to use for invoking the respective service.
<i>from</i>	String	2014-12-29T19:52:13+02:00	The lower limit of the duration of the query.
<i>to</i>	String	2014-12-29T20:52:13+02:00	The upper limit of the duration of the query.

The class diagram of the response (instance of PriceReport) is given in Figure 31, page 119.

2.11.2.1 Retrieve the available energy prices in a trial within a time range [GET]**Request**

- Headers
 1. x-auth-token: `an_auth_token`
 2. Accept: `application/json`

Response 200 (application/json)

- Body
 1. {
 2. "metadata":{
 3. "api_version":"0.1",
 4. "trial":"Malmo",
 5. "created":"2015-01-13T16:07:31+02:00",
 6. "updated":"2015-01-13T16:07:31+02:00"
 7. },
 8. "prices":[
 9. {
 10. "id":"1",
 11. "location_name":"A",
 12. "start_time":"2014-12-29T19:52:13+02:00",
 13. "end_time":"2014-12-29T20:12:13+02:00",
 14. "currency":"Euro",
 15. "electricity_price":"10.7",
 16. "heating_price":"3.6",
 17. "heating_offset":"1"
 18. },
 19. {
 20. "id":"2",
 21. "location_name":"A",
 22. "start_time":"2014-12-29T20:12:13+02:00",
 23. "end_time":"2014-12-29T20:32:13+02:00",
 24. "currency":"Euro",
 25. "electricity_price":"10.7",
 26. "heating_price":"3.6",
 27. "heating_offset":"1"
 28. },
 29. {
 30. "id":"3",

```
31.         "location_name": "A",
32.         "start_time": "2014-12-29T20:32:13+02:00",
33.         "end_time": "2014-12-29T20:52:13+02:00",
34.         "currency": "Euro",
35.         "electricity_price": "10.7",
36.         "heating_price": "3.6",
37.         "heating_offset": "1"
38.     },
39.     {
40.         "id": "4",
41.         "location_name": "B",
42.         "start_time": "2014-12-29T19:52:13+02:00",
43.         "end_time": "2014-12-29T20:12:13+02:00",
44.         "currency": "Euro",
45.         "electricity_price": "10.7",
46.         "heating_price": "3.6",
47.         "heating_offset": "1"
48.     },
49.     {
50.         "id": "5",
51.         "location_name": "B",
52.         "start_time": "2014-12-29T20:12:13+02:00",
53.         "end_time": "2014-12-29T20:32:13+02:00",
54.         "currency": "Euro",
55.         "electricity_price": "10.7",
56.         "heating_price": "3.6",
57.         "heating_offset": "1"
58.     },
59.     {
60.         "id": "6",
61.         "location_name": "B",
62.         "start_time": "2014-12-29T20:32:13+02:00",
63.         "end_time": "2014-12-29T20:52:13+02:00",
64.         "currency": "Euro",
65.         "electricity_price": "10.7",
66.         "heating_price": "3.6",
67.         "heating_offset": "1"
68.     }
69. ]
70. }
```

2.11.3 Get the available energy prices in a trial location, based on its name

Endpoint URL: `/{version}/{trial}/prices/{name}`

Allows a user to get information regarding the energy prices in a location. A valid {name} can be obtained by calling the `/{version}/{trial}/prices` service and checking the `location_name` fields. 'Malmo' is the only trial offering this service.

Parameters

Name	Type	Example	Description
<i>version</i>	String	v0.1	The version of the API to use.
<i>trial</i>	String	Malmö	The trial infrastructure to use for invoking the respective service.
<i>name</i>	String	A	The name of the location to get pricing data for.

The class diagram of the response (instance of PriceReport) is given in Figure 31, page 119.

2.11.3.1 Retrieve the available energy prices in a trial location, based on its name [GET]**Request**

- Headers
 1. x-auth-token: `an_auth_token`
 2. Accept: `application/json`

Response 200 (application/json)

- Body
 1. {
 2. "metadata":{
 3. "api_version":"0.1",
 4. "trial":"Malmö",
 5. "created":"2015-01-13T16:09:35+02:00",
 6. "updated":"2015-01-13T16:09:35+02:00"
 7. },
 8. "prices":[
 9. {
 10. "id":"1",
 11. "location_name":"A",
 12. "start_time":"2015-01-13T15:09:35+02:00",
 13. "end_time":"2015-01-13T16:09:35+02:00",
 14. "currency":"Euro",
 15. "electricity_price":"10.7",
 16. "heating_price":"3.6",
 17. "heating_offset":"1"
 18. }
 19.]
 20. }

2.11.4 Get the available energy prices within a time range in a trial location, based on its name

Endpoint URL: `/{version}/{trial}/prices/{name}/{from}/{to}`

Allows a user to get information regarding the energy prices in a location. A valid {name} can be obtained by calling the `/{version}/{trial}/prices` service and checking the `location_name` fields. Valid {from} and {to} values are expressed in ISO8601 format. 'Malmö' is the only trial offering this service.

Parameters

Name	Type	Example	Description
<i>version</i>	String	v0.1	The version of the API to use.
<i>trial</i>	String	Malmö	The trial infrastructure to use for invoking the respective service.
<i>name</i>	String	A	The name of the location to get pricing data for.
<i>from</i>	String	2014-12-29T19:52:13+02:00	The lower limit of the duration of the query, in an ISO8601 compliant format
<i>to</i>	String	2014-12-29T20:52:13+02:00	The upper limit of the duration of the query, in an ISO8601 compliant format

The class diagram of the response (instance of PriceReport) is given in Figure 31, page 119.

2.11.4.1 Retrieve the available energy prices within a time range in a trial location, based on its name [GET]

Request

- Headers
 1. x-auth-token: `an_auth_token`
 2. Accept: `application/json`

Response 200 (application/json)

- Body
 1. {
 2. "metadata":{
 3. "api_version":"0.1",
 4. "trial":"Malmö",
 5. "created":"2015-01-13T16:14:12+02:00",
 6. "updated":"2015-01-13T16:14:12+02:00"
 7. },
 8. "prices":[
 9. {
 10. "id":"1",
 11. "location_name":"A",
 12. "start_time":"2015-01-13T15:14:12+02:00",
 13. "end_time":"2014-12-29T19:52:13+02:00",
 14. "currency":"Euro",
 15. "electricity_price":"10.7",
 16. "heating_price":"3.6",
 17. "heating_offset":"1"
 18. },
 19. {
 20. "id":"2",
 21. "location_name":"A",
 22. "start_time":"2015-01-13T15:14:12+02:00",
 23. "end_time":"2014-12-29T20:22:13+02:00",
 24. "currency":"Euro",

```

25.         "electricity_price": "10.7",
26.         "heating_price": "3.6",
27.         "heating_offset": "1"
28.     },
29.     {
30.         "id": "3",
31.         "location_name": "A",
32.         "start_time": "2015-01-13T15:14:12+02:00",
33.         "end_time": "2014-12-29T20:52:13+02:00",
34.         "currency": "Euro",
35.         "electricity_price": "10.7",
36.         "heating_price": "3.6",
37.         "heating_offset": "1"
38.     }
39. ]
40. }
    
```

2.11.5 Get the price locations available to the user

Endpoint URL: [/{version}/{trial}/prices/locations]

Allows a user to get information regarding the price locations available to the user. 'Malmo' is the only trial offering this service.

Parameters

Name	Type	Example	Description
version	String	v0.1	The version of the API to use.
trial	String	Malmo	The trial infrastructure to use for invoking the respective service.

The class diagram of the response (instance of PriceLocationReport) is given in Figure 32.

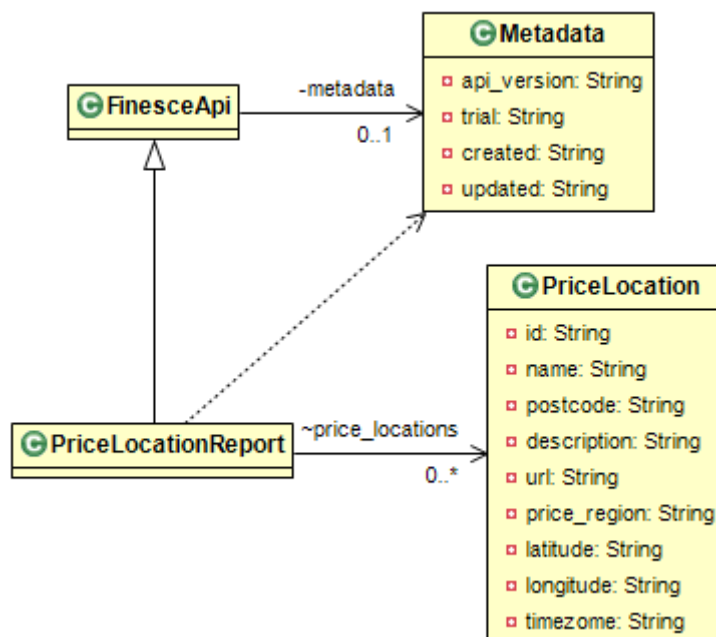

Figure 32: Class diagram of a PriceLocationReport response

The attributes of the relevant response class are detailed in the following tables.

Table 57: Attributes of the PriceLocationReport class

Name	Type	Description
metadata	Metadata	The metadata of the report (see Table 5, page 15)
price_locations	List<PriceLocation>	The price locations of the trial (see Table 58, page 126)

Table 58: Attributes of the PriceLocation class

Name	Type	Description
id	String	The id of the price location
name	String	The name of the price location
postcode	String	The post code of the price location
description	String	A description of the price location
url	String	The URL of the price location (if any)
price_region	String	The name of the price region this location belongs to (if any)
latitude	String	The latitude of the centre of this location
longitude	String	The longitude of the centre of this location
timezone	String	The timezone of the price location

2.11.5.1 Retrieve the price locations available to the user [GET]**Request**

- Headers
 1. x-auth-token: `an_auth_token`
 2. Accept: `application/json`

Response 200 (application/json)

- Body
 1. {
 2. "metadata":{
 3. "api_version":"0.1",
 4. "trial":"Malmo",
 5. "created":"2015-01-13T17:00:06+02:00",
 6. "updated":"2015-01-13T17:00:06+02:00"
 7. },
 8. "price_locations":[
 9. {
 10. "id":"1",
 11. "name":"A",
 12. "postcode":"A1234",
 13. "description":"Description of price location A",
 14. "url":"http://www.random_url.rnd/A",
 15. "price_region":"Price Region A",
 16. "latitude":"55.605833",
 17. "longitude":"13.035833",
 18. "timezone":"GMT+1"
 19. },
 20. {
 21. "id":"2",
 22. "name":"B",
 23. "postcode":"B1234",
 24. "description":"Description of price location B",
 25. "url":"http://www.random_url.rnd/B",
 26. "price_region":"Price Region B",
 27. "latitude":"55.605833",
 28. "longitude":"13.035833",

```

29.         "timezome": "GMT+1"
30.     }
31. ]
32. }

```

2.11.6 Get a price location based on its name

Endpoint URL: `[/{version}]/{trial}/prices/locations/{name}`

Allows a user to get information regarding a price location available to the user, based on the location name. A valid {name} can be obtained by calling the `[/{version}]/{trial}/prices/locations` service. 'Malmo' is the only trial offering this service.

Parameters

Name	Type	Example	Description
<i>version</i>	String	v0.1	The version of the API to use.
<i>trial</i>	String	Malmo	The trial infrastructure to use for invoking the respective service.
<i>name</i>	String	A	The name of the location to get information for.

The class diagram of the response (instance of PriceLocationReport) is given in Figure 32, page 125.

2.11.6.1 Retrieve a price location based on its name [GET]

Request

- Headers
 1. x-auth-token: `an_auth_token`
 2. Accept: `application/json`

Response 200 (application/json)

- Body
 1. {
 2. "metadata":{
 3. "api_version": "0.1",
 4. "trial": "Malmo",
 5. "created": "2015-01-13T17:00:06+02:00",
 6. "updated": "2015-01-13T17:00:06+02:00"
 7. },
 8. "price_location":[
 9. {
 10. "id": "1",
 11. "name": "A",
 12. "postcode": "A1234",
 13. "description": "Description of price location A",
 14. "url": "http://www.random_url.rnd/A",
 15. "price_region": "Price Region A",
 16. "latitude": "55.605833",
 17. "longitude": "13.035833",
 18. "timezome": "GMT+1"
 19. }
 20.]
 21. }

2.11.7 Get a data stream for all the available pricing locations

Endpoint URL: [/{version}/{trial}/prices/locations/data/]

Allows a user to get information regarding a data stream available for locations associated with the current user. 'Malmo' is the only trial offering this service.

Parameters

Name	Type	Example	Description
version	String	v0.1	The version of the API to use.
trial	String	Malmo	The trial infrastructure to use for invoking the respective service.

The class diagram of the response (instance of PriceLocationReport) is given in Figure 33.

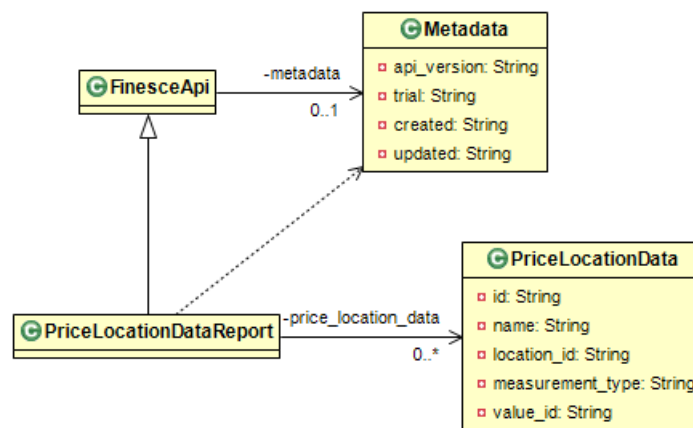

Figure 33: Class diagram of a PriceLocationDataReport response

The attributes of the respective response class are detailed in the following tables.

Table 59: Attributes of the PriceLocationDataReport class

Name	Type	Description
metadata	Metadata	The metadata of the report (see Table 5, page 15)
price_location_data	List<PriceLocationData>	The list of value objects required (see Table 60, page 128)

Table 60: Attributes of the PriceLocationData class

Name	Type	Description
id	String	The id of the price location data object
name	String	The name of the price location data object
location_id	String	The location id associated with the price location data object (see Table 58, page 126)
measurement_type	String	The measurement type of the price location data object (see page 29 for details)
value_id	String	The id of the value object of the price location data object (see Table 62, page 131)

2.11.7.1 Retrieve a data stream for all the available locations [GET]

Request

- Headers
 1. x-auth-token: `an_auth_token`
 2. Accept: `application/json`

Response 200 (application/json)

- Body
 1. {
 2. "metadata":{
 3. "api_version":"0.1",
 4. "trial":"Malmo",
 5. "created":"2015-01-13T20:04:09+02:00",
 6. "updated":"2015-01-13T20:04:09+02:00"
 7. },
 8. "price_location_data":[
 9. {
 10. "id":null,
 11. "name":"A",
 12. "location_id":"1",
 13. "measurement_type":"LocationHeatPowerDemandGrid",
 14. "value_id":"1"
 15. },
 16. {
 17. "id":null,
 18. "name":"B",
 19. "location_id":"2",
 20. "measurement_type":"LocationHeatPowerConsumptionGrid",
 21. "value_id":"2"
 22. }
 23.]
 24. }

2.11.8 Get a data stream for a specific pricing location

Endpoint URL: `/{version}/{trial}/prices/locations/data/{name}`

Allows a user to get information regarding a data stream available for locations associated with the current user. A valid {name} can be obtained by calling the `/{version}/{trial}/prices/locations` service. 'Malmo' is the only trial offering this service.

Parameters

Name	Type	Example	Description
<i>version</i>	String	v0.1	The version of the API to use.
<i>trial</i>	String	Malmo	The trial infrastructure to use for invoking the respective service.
<i>name</i>	String	A	The name of the pricing location to ask information for.

The class diagram of the response (instance of PriceLocationReport) has been already given in Figure 33, page 128.

2.11.8.1 Retrieve a data stream associated with a pricing location [GET]

Request

- Headers
 1. x-auth-token: `an_auth_token`
 2. Accept: `application/json`

Response 200 (application/json)

- Body
 1. {
 2. "metadata":{
 3. "api_version":"0.1",
 4. "trial":"Malmo",
 5. "created":"2015-01-13T20:04:09+02:00",
 6. "updated":"2015-01-13T20:04:09+02:00"
 7. },
 8. "price_location_data":[
 9. {
 10. "id":null,
 11. "name":"A",
 12. "location_id":"1",
 13. "measurement_type":"LocationHeatPowerDemandGrid",
 14. "value_id":"1"
 15. }
 16.]
 17. }

2.11.9 Get a data stream for a specific pricing location, for a specific period of time

Endpoint URL: `/{version}/{trial}/prices/locations/data/{name}/{from}/{to}`

Allows a user to get information regarding a data stream available for locations associated with the current user. A valid `{name}` can be obtained by calling the `/{version}/{trial}/prices/locations` service. 'Malmo' is the only trial offering this service.

Parameters

Name	Type	Example	Description
<i>version</i>	String	v0.1	The version of the API to use.
<i>trial</i>	String	Malmo	The trial infrastructure to use for invoking the respective service.
<i>name</i>	String	A	The name of the pricing location to ask information for.
<i>from</i>	String	2014-12-29T19:52:13+02:00	The lower limit of the duration of the query, in an ISO8601 compliant format.
<i>to</i>	String	2014-12-29T20:52:13+02:00	The upper limit of the duration of the query, in an ISO8601 compliant format

The class diagram of the response (instance of PriceLocationDataValueReport) are given in Figure 34.

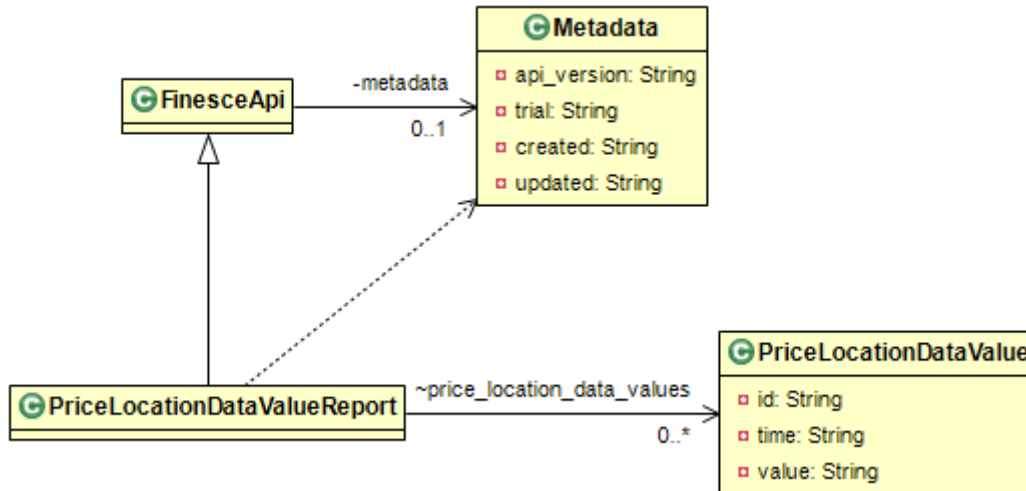

Figure 34: Class diagram of a PriceLocationDataValueReport response.

The attributes of the relevant response class are detailed in the following tables.

Table 61: Attributes of the PriceLocationDataValueReport class

Name	Type	Description
metadata	Metadata	The metadata of the report (see Table 5, page 15)
price_location_data_values	List<PriceLocationDataValue>	The list of data values associated with the price location (see Table 62, page 131)

Table 62: Attributes of the PriceLocationDataValue class

Name	Type	Description
id	String	The id of the data value
time	String	The time of the measurement, in an ISO8601 compliant format
value	String	The actual value of the measurement

2.11.9.1 Retrieve a data stream associated with a pricing location for a specific period of time [GET]

Request

- Headers
 1. x-auth-token: `an_auth_token`
 2. Accept: `application/json`

Response 200 (application/json)

- Body
 1. {
 2. "metadata":{
 3. "api_version":"0.1",
 4. "trial":"Malmo",
 5. "created":"2015-01-13T20:09:00+02:00",
 6. "updated":"2015-01-13T20:09:00+02:00"
 7. },

```
8.   "price_location_data_values":[
9.     {
10.       "id":"1",
11.       "time":"2014-12-29T19:52:13+02:00",
12.       "value":"1234"
13.     },
14.     {
15.       "id":"2",
16.       "time":"2014-12-29T20:22:13+02:00",
17.       "value":"1235"
18.     },
19.     {
20.       "id":"3",
21.       "time":"2014-12-29T20:52:13+02:00",
22.       "value":"1236"
23.     }
24.   ]
25. }
```

2.12 Regional Energy-Related Information

This API set offers services related to regional information related to energy resources.

2.12.1 Get the available regions

Endpoint URL: [/{version}/{trial}/regions]

Allows a user to retrieve a collection of regions supported by the trial. 'Ireland' is the only trial offering this service.

Parameters

Name	Type	Example	Description
version	String	v0.1	The version of the API to use.
trial	String	Ireland	The trial infrastructure to use for getting the trial regions

The class diagram of the response (instance of RegionsReport) is given in Figure 35.

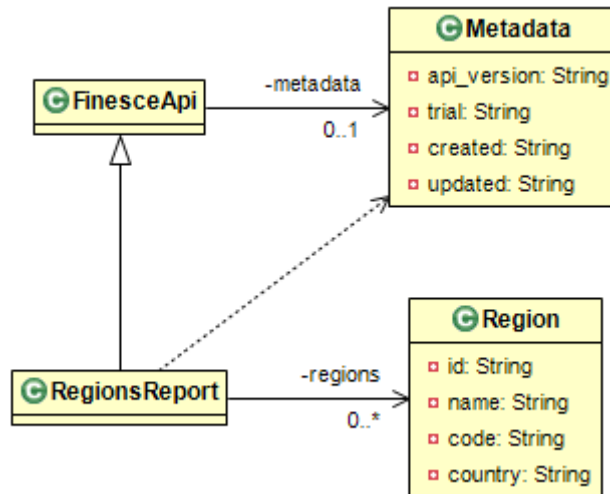

Figure 35: Class diagram of a RegionsReport response.

The attributes of the relevant response are detailed in the tables following.

Table 63: Attributes of the RegionsReport class

Name	Type	Description
metadata	Metadata	The metadata of the report (see Table 5, page 15)
regions	List<Region>	The regions supported by the trial (see Table 64, page 133)

Table 64: Attributes of the Region class

Name	Type	Description
id	String	The id of the region
name	String	The name of the region
code	String	The code of the region
country	String	The country of the region

2.12.1.1 Retrieve the available trial regions [GET]

Request

- Headers
 1. x-auth-token: `an_auth_token`
 2. Accept: `application/json`

Response 200 (application/json)

- Body
 1. {
 2. "metadata":{
 3. "api_version":"0.1",
 4. "trial":"Ireland",
 5. "created":"2015-01-12T18:05:27+01:00",
 6. "updated":"2015-01-12T18:05:27+01:00"
 7. },
 8. "regions":[
 9. {
 10. "id":"1",
 11. "name":"Region 1",
 12. "code":"R1",
 13. "country":"Ireland"
 14. },
 15. {
 16. "id":"2",
 17. "name":"Region 2",
 18. "code":"R2",
 19. "country":"Ireland"
 20. }
 21.]
 22. }

2.12.2 Get a region based on its ID

Endpoint URL: `/{version}/{trial}/regions/{id}`

Allows a user to retrieve a region record, based on its ID. A valid {id} can be obtained by calling the `/{version}/{trial}/regions` service. 'Ireland' is the only trial offering this service.

Parameters

Name	Type	Example	Description
<i>version</i>	String	v0.1	The version of the API to use.
<i>trial</i>	String	Ireland	The trial infrastructure to use for getting the desired region
<i>id</i>	String	1	The id of the region to get information for.

The class diagram of the response (instance of `RegionsReport`) has been already presented in Figure 35, page 133.

2.12.2.1 Retrieve a specific region based on its ID [GET]

Request

- Headers
 1. x-auth-token: `an_auth_token`
 2. Accept: `application/json`

Response 200 (application/json)

- Body
 1. {
 2. "metadata": {
 3. "api_version": "0.1",
 4. "trial": "Ireland",
 5. "created": "2015-01-12T18:07:12+01:00",
 6. "updated": "2015-01-12T18:07:12+01:00"
 7. },
 8. "region": [
 9. {
 10. "id": "1",
 11. "name": "Region 1",
 12. "code": "R1",
 13. "country": "Ireland"
 14. }
 15.]
 16. }

2.12.3 Get the algorithmic optimization weights associated with a region

Endpoint URL: [/version/trial/regions/{id}/algoweights]

Allows a user to retrieve the algorithm weights set associated with a region. A valid {id} can be obtained by calling the /version/trial/regions service. 'Ireland' is the only trial offering this service.

Parameters

Name	Type	Example	Description
version	String	v0.1	The version of the API to use.
trial	String	Ireland	The trial infrastructure to use for getting the algoweight objects
id	String	1	The id of the region to get the algorithm weights set for.

The class diagram of the response (AlgoweightReport) has been already presented in Figure 19, page 58.

2.12.3.1 Retrieve the algorithmic optimization weights associated with a region [GET]

Request

- Headers
 1. x-auth-token: `an_auth_token`
 2. Accept: `application/json`

Response 200 (application/json)

- Body
 1. {
 2. "metadata": {
 3. "api_version": "0.1",

```

4.     "trial": "Ireland",
5.     "created": "2015-01-12T18:09:27+01:00",
6.     "updated": "2015-01-12T18:09:27+01:00"
7.   },
8.   "algoweights": [
9.     {
10.      "id": "1",
11.      "renewables": "100.0",
12.      "interconnect": "0.0",
13.      "specific": "0.0",
14.      "timeslot_id": "1",
15.      "region_id": "1"
16.    }
17.  ]
18.}

```

2.12.4 Get an energy report associated with a region

Endpoint URL: `[/{version}/{trial}/regions/{id}/energy]`

Allows a user to retrieve a collection of aggregated regional electric vehicle supply equipment (EVSE) energy records. A valid {id} can be obtained by calling the `[/{version}/{trial}/regions]` service. 'Ireland' is the only trial offering this service.

Parameters

Name	Type	Example	Description
<i>version</i>	String	v0.1	The version of the API to use.
<i>trial</i>	String	Ireland	The trial infrastructure to use for getting the regional energy report
<i>id</i>	String	1	The id of the region for which to get the energy report.

The class diagram of the response (RegionalEnergyReport) has been already presented in Figure 21, page 61.

2.12.4.1 Retrieve an energy report associated with a region [GET]

Request

- Headers

1. x-auth-token: `an_auth_token`
2. Accept: `application/json`

Response 200 (application/json)

- Body

```

1. {
2.   "metadata":{
3.     "api_version":"0.1",
4.     "trial":"Ireland",
5.     "created":"2015-01-13T11:36:57+02:00",
6.     "updated":"2015-01-13T11:36:57+02:00"

```



```

7.     },
8.     "regional_energy":[
9.         {
10.            "id":"1",
11.            "generated_energy":5001.57,
12.            "aggregated_energy":6500.36,
13.            "requested_energy":150.69,
14.            "actual_energy":210.67,
15.            "forecasted_energy":6300,
16.            "region_id":"1",
17.            "timeslot_id":"1"
18.        }
19.    ]
20. }
    
```

2.12.5 Get an average energy report associated with a region

Endpoint URL: [/{version}/{trial}/regions/{id}/energy/avg]

Allows a user to retrieve a collection of aggregate regional electric vehicle supply equipment (EVSE) energy records associated with a region, based on its ID. A valid {id} can be obtained by calling the /{version}/{trial}/regions service. 'Ireland' is the only trial offering this service.

Parameters

Name	Type	Example	Description
version	String	v0.1	The version of the API to use.
trial	String	Ireland	The trial infrastructure to use for getting the average regional energy report
id	String	1	The id of the region for which to get the average energy report.

The class diagram of the response (instance of RegionalEnergyAvgReport) is given in Figure 36.

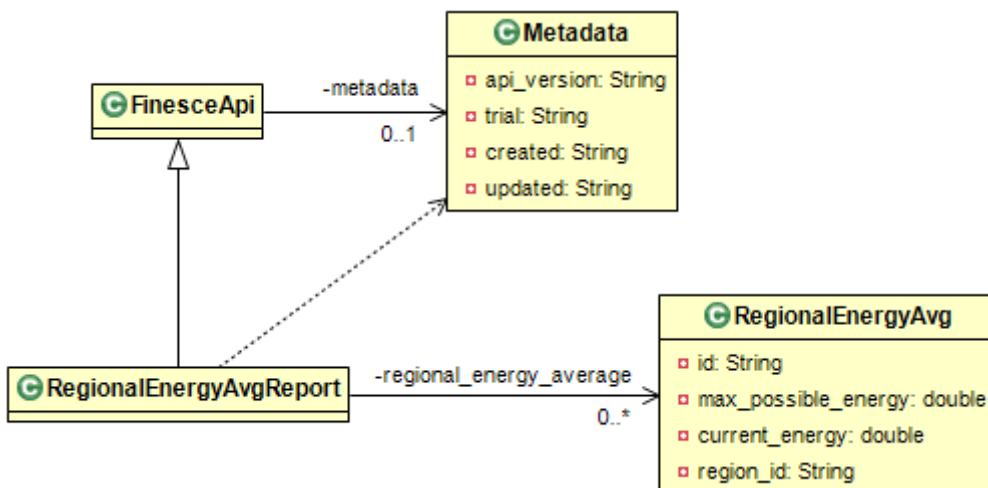

Figure 36: Class diagram of a RegionalEnergyAvgReport response

The attributes of the relevant response are detailed in the tables following.

Table 65: Attributes of the RegionalEnergyAvgReport class

Name	Type	Description
metadata	Metadata	The metadata of the report (see Table 5, page 15)
regional_energy_average	List<RegionalEnergyAvg>	The list of current average regional reports (see Table 66, page 138)

Table 66: Attributes of the RegionalEnergyAvg class

Name	Type	Description
id	String	The id of the specific measurement
max_possible_energy	double	The maximum possible energy of the region
current_energy	double	The current average energy of the region
region_id	String	The region id (see Table 64, page 133)

2.12.5.1 Retrieve an average energy report associated with a region [GET]

Request

- Headers
 1. x-auth-token: `an_auth_token`
 2. Accept: `application/json`

Response 200 (application/json)

- Body
 1. {
 2. "metadata":{
 3. "api_version":"0.1",
 4. "trial":"Ireland",
 5. "created":"2015-01-13T11:42:21+02:00",
 6. "updated":"2015-01-13T11:42:21+02:00"
 7. },
 8. "regional_energy_average":[
 9. {
 10. "id":"1",
 11. "max_possible_energy":6.16,
 12. "current_energy":4.56,
 13. "region_id":"1"
 14. }
 15.]
 16. }

2.12.6 Get the EVSE entities associated with a region

Endpoint URL: `/{version}/{trial}/regions/{id}/supply_equipment`

Allows a user to retrieve a collection of electric vehicle supply equipment (EVSE) entities associated with a region. A valid {id} can be obtained by calling the `/{version}/{trial}/regions` service. 'Ireland' is the only trial offering this service.

Parameters

Name	Type	Example	Description
<i>version</i>	String	v0.1	The version of the API to use.
<i>trial</i>	String	Ireland	The trial infrastructure to use for getting the EVSE details.
<i>id</i>	String	1	The id of the region for which to get the EVSE report.

The class diagram of the response (instance of `VehicleSupplyEquipmentReport`) has been already given in Figure 26, page 92.

2.12.6.1 Retrieve the EVSE entities associated with a region [GET]**Request**

- Headers
 1. x-auth-token: `an_auth_token`
 2. Accept: `application/json`

Response 200 (application/json)

- Body
 1. {
 2. "metadata":{
 3. "api_version":"0.1",
 4. "trial":"Ireland",
 5. "created":"2015-01-13T11:44:06+02:00",
 6. "updated":"2015-01-13T11:44:06+02:00"
 7. },
 8. "evses":[
 9. {
 10. "id":"1",
 11. "manufacturer":"M2C",
 12. "model":"M2C",
 13. "hw_version":"1.0",
 14. "fw_version":"1.0",
 15. "region_id":"1"
 16. }
 17.]
 18. }

2.12.7 Get the energy status of the trial regions

Endpoint URL: `[/{version}]/{trial}/energy/regional]`

Allows a user to retrieve a list of regional energy data objects. 'Ireland' is the only trial offering this service.

Parameters

Name	Type	Example	Description
<i>version</i>	String	v0.1	The version of the API to use.
<i>trial</i>	String	Ireland	The trial infrastructure to use for retrieving the regional energy data.

The class diagram of the response (instance of RegionalEnergyReport) has been already given in Figure 21, page 61.

2.12.7.1 Retrieve the energy status of the trial regions [GET]**Request**

- Headers
 1. x-auth-token: **an_auth_token**
 2. Accept: **application/json**

Response 200 (application/json)

- Body
 1. {
 2. "metadata":{
 3. "api_version":"0.1",
 4. "trial":"Ireland",
 5. "created":"2015-01-20T17:33:59+02:00",
 6. "updated":"2015-01-20T17:33:59+02:00"
 7. },
 8. "regional_energy":[
 9. {
 10. "id":"1",
 11. "generated_energy":5001.57,
 12. "aggregated_energy":6500.36,
 13. "requested_energy":150.69,
 14. "actual_energy":210.67,
 15. "forecasted_energy":6300,
 16. "region_id":"1",
 17. "timelslot_id":"1"
 18. },
 19. {
 20. "id":"2",
 21. "generated_energy":4808.69,
 22. "aggregated_energy":6200,
 23. "requested_energy":178,
 24. "actual_energy":130.78,
 25. "forecasted_energy":6200,
 26. "region_id":"2",
 27. "timelslot_id":"1"
 28. }
 29.]
 30. }

2.12.8 Get the energy status of a region

Endpoint URL: `[/{version}/{trial}/energy/regional/{id}]`

Allows a user to retrieve a regional energy record. A valid {id} can be obtained by calling the `[/{version}/{trial}/energy/regional]` service. 'Ireland' is the only trial offering this service.

Parameters

Name	Type	Example	Description
<code>version</code>	String	v0.1	The version of the API to use.
<code>trial</code>	String	Ireland	The trial infrastructure to use for retrieving the regional energy data.
<code>id</code>	String	1	The id of the regional energy record to be retrieved.

The class diagram of the response (instance of `RegionalEnergyReport`) has been already given in Figure 21, page 61.

2.12.8.1 Retrieve the energy status of a region [GET]

Request

- Headers
 1. `x-auth-token`: `an_auth_token`
 2. `Accept`: `application/json`

Response 200 (application/json)

- Body
 1. {
 2. "metadata":{
 3. "api_version":"0.1",
 4. "trial":"Ireland",
 5. "created":"2015-01-20T17:33:59+02:00",
 6. "updated":"2015-01-20T17:33:59+02:00"
 7. },
 8. "regional_energy":[
 9. {
 10. "region_id":"1",
 11. "generated_energy":5001.57,
 12. "aggregated_energy":6500.36,
 13. "requested_energy":150.69,
 14. "actual_energy":210.67,
 15. "forecasted_energy":6300,
 16. "region_id":"1",
 17. "timelslot_id":"1"
 18. }
 19.]
 20. }

2.12.9 Get a region associated with a regional energy record

Endpoint URL: `[/{version}/{trial}/energy/regional/{id}/region]`

Allows a user to retrieve a region associated with a regional energy record. A valid {id} can be obtained by calling the `[/{version}/{trial}/energy/regional]` service. 'Ireland' is the only trial offering this service.

Parameters

Name	Type	Example	Description
<code>version</code>	String	v0.1	The version of the API to use.
<code>trial</code>	String	Ireland	The trial infrastructure to use for retrieving the region.
<code>id</code>	String	1	The id of the regional energy record for which the region details will be retrieved.

The class diagram of the response (instance of RegionsReport) has been already given in Figure 35, page 133.

2.12.9.1 Retrieve a region associated with a regional energy record [GET]

Request

- Headers
 1. x-auth-token: `an_auth_token`
 2. Accept: `application/json`

Response 200 (application/json)

- Body
 1. {
 2. "metadata":{
 3. "api_version":"0.1",
 4. "trial":"Ireland",
 5. "created":"2015-01-12T18:05:27+01:00",
 6. "updated":"2015-01-12T18:05:27+01:00"
 7. },
 8. "regions":[
 9. {
 10. "id":"1",
 11. "name":"Region 1",
 12. "code":"R1",
 13. "country":"Ireland"
 14. }
 15.]
 16. }

2.12.10 Get a timeslot associated with a regional energy record

Endpoint URL: `[/{version}/{trial}/energy/regional/{id}/timeslot]`

Allows a user to retrieve a timeslot associated with a regional energy record. A valid {id} can be obtained by calling the `/{version}/{trial}/energy/regional` service. 'Ireland' is the only trial offering this service.

Parameters

Name	Type	Example	Description
<i>version</i>	String	v0.1	The version of the API to use.
<i>trial</i>	String	Ireland	The trial infrastructure to use for retrieving the timeslot.
<i>id</i>	String	1	The id of the regional energy record for which the timeslot details will be retrieved.

The class diagram of the response (instance of TimeslotsReport) has been already given in Figure 18, page 55.

2.12.10.1 Retrieve a timeslot associated with a regional energy record [GET]

Request

- Headers
 1. x-auth-token: `an_auth_token`
 2. Accept: `application/json`

Response 200 (application/json)

- Body
 1. {
 2. "metadata":{
 3. "api_version":"0.1",
 4. "trial":"Ireland",
 5. "created":"2015-01-13T13:51:07+02:00",
 6. "updated":"2015-01-13T13:51:07+02:00"
 7. },
 8. "timeslots":[
 9. {
 10. "id":"1",
 11. "start":"2014-12-20T02:15:00+02:00",
 12. "duration":15
 13. }
 14.]
 15. }

2.12.11 Get the average EVSE regional energy records

Endpoint URL: `/{version}/{trial}/energy/regional/avg`

Allows a user to retrieve a collection of aggregated regional electric vehicle supply equipment (EVSE) energy records. 'Ireland' is the only trial offering this service.

Parameters

Name	Type	Example	Description
<i>version</i>	String	v0.1	The version of the API to use.
<i>trial</i>	String	Ireland	The trial infrastructure to use for retrieving the aggregated energy data.

The class diagram of the response (instance of `RegionalEnergyAvgReport`) has been already given in Figure 36, page 137.

2.12.11.1 Retrieve the average EVSE regional energy records [GET]

Request

- Headers
 1. x-auth-token: `an_auth_token`
 2. Accept: `application/json`

Response 200 (application/json)

- Body
 1. {
 2. "metadata":{
 3. "api_version":"0.1",
 4. "trial":"Ireland",
 5. "created":"2015-01-20T18:25:22+02:00",
 6. "updated":"2015-01-20T18:25:22+02:00"
 7. },
 8. "regional_energy_average":[
 9. {
 10. "id":"1",
 11. "max_possible_energy":6.16,
 12. "current_energy":4.56,
 13. "region_id":"1"
 14. },
 15. {
 16. "id":"2",
 17. "max_possible_energy":9.58,
 18. "current_energy":3.04,
 19. "region_id":"2"
 20. }
 21.]
 22. }

2.12.12 Get an average EVSE regional energy record

Endpoint URL: `/{version}/{trial}/energy/regional/{id}/avg/{id}`

Allows a user to retrieve an aggregated regional electric vehicle supply equipment (EVSE) energy record. A valid `{id}` can be obtained by calling the `/{version}/{trial}/energy/regional` service. 'Ireland' is the only trial offering this service.

Parameters

Name	Type	Example	Description
<i>version</i>	String	v0.1	The version of the API to use.
<i>trial</i>	String	Ireland	The trial infrastructure to use for retrieving the aggregated energy data.
<i>id</i>	String	1	The id of the regional energy record for which the average energy reports will be retrieved.

The class diagram of the response (instance of `RegionalEnergyAvgReport`) has been already given in Figure 36, page 137.

2.12.12.1 Retrieve an average EVSE regional energy record [GET]**Request**

- Headers
 1. x-auth-token: `an_auth_token`
 2. Accept: `application/json`

Response 200 (application/json)

- Body
 1. {
 2. "metadata":{
 3. "api_version":"0.1",
 4. "trial":"Ireland",
 5. "created":"2015-01-20T18:25:22+02:00",
 6. "updated":"2015-01-20T18:25:22+02:00"
 7. },
 8. "regional_energy_average":[
 9. {
 10. "id":"1",
 11. "max_possible_energy":6.16,
 12. "current_energy":4.56,
 13. "region_id":"1"
 14. }
 15.]
 16. }

2.13 Simulation

This set of APIs may be used to retrieve simulated values for various smart grid/city aspects.

2.13.1 Get prediction of user power demand

Endpoint

URL:

`[/]{version}/{trial}/simulation/prediction/power/demand/user/{customer_id}`

Returns a simulated power demand prediction for a specific user, based on his/her id.

Parameters

Name	Type	Example	Description
version	String	v0.1	The version of the API to use.
trial	String	Terni	The trial infrastructure to use for retrieving the aggregated energy data.
customer_id	String	WP4_U_3	The user id to fetch the predictions for.

The class diagram of the report (instance of PredictionReport) is given in Figure 37.

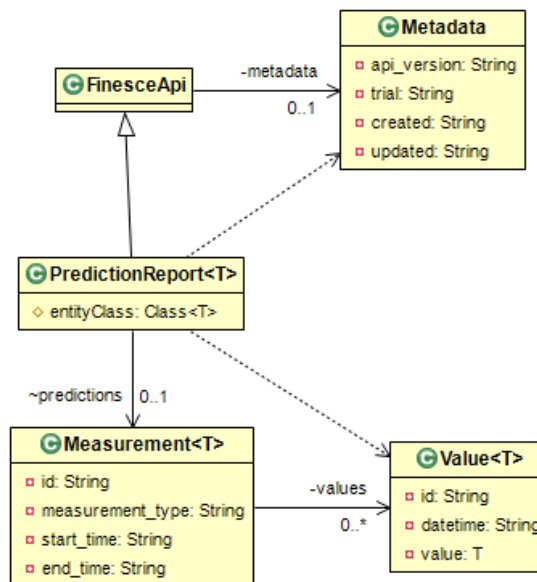

Figure 37: Class diagram of a PredictionReport response

In practice, a PredictionReport is an alternative of the MeasurementReport class, following the exact same class structure and working in exactly the same way (see Figure 10, page 28 for details).

2.13.1.1 Retrieve a report related to the predicted user power demand [GET]

Request

- Headers
 1. x-auth-token: `an_auth_token`
 2. Accept: `application/json`

Response 200 (application/json)

- Body

```

1. {
2.   "metadata":{
3.     "api_version":"0.1",
4.     "trial":"Terni",
5.     "created":"2015-01-22T11:46:40+02:00",
6.     "updated":"2015-01-22T11:46:40+02:00"
7.   },
8.   "predictions":[
9.     {
10.      "id":"WP4_U_3",
11.      "measurement_type":"PowerDemandGrid",
12.      "values":[
13.        {
14.          "id":null,
15.          "datetime":"2015-01-21T10:16:27+02:00",
16.          "value":0.0
17.        },
18.        {
19.          "id":null,
20.          "datetime":"2015-01-21T12:16:27+02:00",
21.          "value":0.0
22.        },
23.        {
24.          "id":null,
25.          "datetime":"2015-01-21T15:16:27+02:00",
26.          "value":0.0
27.        },
28.        {
29.          "id":null,
30.          "datetime":"2015-01-21T21:16:27+02:00",
31.          "value":0.0
32.        },
33.        {
34.          "id":null,
35.          "datetime":"2015-01-22T09:16:27+02:00",
36.          "value":0.0
37.        }
38.      ],
39.      "start_time":null,
40.      "end_time":null
41.    }
42.  ]
43. }

```

2.13.2 Get prediction of sector power demand

Endpoint URL: `[/{version}]/{trial}/simulation/prediction/power/demand/sector/{sector}`

Returns a simulated power demand prediction for a specific sector.

Parameters

Name	Type	Example	Description
<i>version</i>	String	v0.1	The version of the API to use.
<i>trial</i>	String	Terni	The trial infrastructure to use for invoking the respective service.
<i>sector</i>	String	INDUSTRIAL	The sector to fetch the predictions for.

The class diagram of the response (instance of PredictionReport) has been already presented in Figure 37, page 146.

2.13.2.1 Retrieve a report related to the predicted sector power demand [GET]**Request**

- Headers
 1. x-auth-token: `an_auth_token`
 2. Accept: `application/json`

Response 200 (application/json)

- Body
 1. {
 2. "metadata":{
 3. "api_version":"0.1",
 4. "trial":"Terni",
 5. "created":"2015-01-22T11:48:15+02:00",
 6. "updated":"2015-01-22T11:48:15+02:00"
 7. },
 8. "predictions ":[
 9. {
 10. "id":"INDUSTRIAL",
 11. "measurement_type":"PowerDemandGrid",
 12. "values":[
 13. {
 14. "id":null,
 15. "datetime":"2015-01-21T10:16:27+02:00",
 16. "value":0.0
 17. },
 18. {
 19. "id":null,
 20. "datetime":"2015-01-21T12:16:27+02:00",
 21. "value":0.0
 22. },
 23. {
 24. "id":null,
 25. "datetime":"2015-01-21T15:16:27+02:00",
 26. "value":0.0
 27. },
 28. {
 29. "id":null,
 30. "datetime":"2015-01-21T21:16:27+02:00",
 31. "value":0.0
 32. },
 33.]

```

34.         "id":null,
35.         "datetime":"2015-01-22T09:16:27+02:00",
36.         "value":0.0
37.     }
38.     ],
39.     "start_time":null,
40.     "end_time":null
41. }
42. ]
43. }

```

2.13.3 Get prediction of user power supply

Endpoint URL: `[/{version}/{trial}/simulation/prediction/power/supply/user/{customer_id}]`

Returns a simulated power supply prediction for a specific user, based on his/her id.

Parameters

Name	Type	Example	Description
<i>version</i>	String	v0.1	The version of the API to use.
<i>trial</i>	String	Terni	The trial infrastructure to use for invoking the respective service.
<i>customer_id</i>	String	WP4_U_3	The user id to fetch the predictions for.

The class diagram of the response (instance of PredictionReport) has been already presented in Figure 37, page 146.

2.13.3.1 Retrieve a report related to the predicted user power supply [GET]

Request

- Headers
 1. x-auth-token: `an_auth_token`
 2. Accept: `application/json`

Response 200 (application/json)

- Body
 1. {
 2. "metadata":{
 3. "api_version":"0.1",
 4. "trial":"Terni",
 5. "created":"2015-01-22T11:49:31+02:00",
 6. "updated":"2015-01-22T11:49:31+02:00"
 7. },
 8. "predictions":[
 9. {
 10. "id":"WP4_U_3",
 11. "measurement_type":"PowerSupplyGrid",
 12. "values":[
 13. {
 14. "id":null,
 15. "datetime":"2015-01-21T10:16:27+02:00",

```

16.         "value":0.0
17.     },
18.     {
19.         "id":null,
20.         "datetime":"2015-01-21T12:16:27+02:00",
21.         "value":0.0
22.     },
23.     {
24.         "id":null,
25.         "datetime":"2015-01-21T15:16:27+02:00",
26.         "value":0.0
27.     },
28.     {
29.         "id":null,
30.         "datetime":"2015-01-21T21:16:27+02:00",
31.         "value":0.0
32.     },
33.     {
34.         "id":null,
35.         "datetime":"2015-01-22T09:16:27+02:00",
36.         "value":0.0
37.     }
38. ],
39. "start_time":null,
40. "end_time":null
41. }
42. ]
43. }

```

2.13.4 Get prediction of sector power supply

Endpoint URL: `[/]{version}/{trial}/simulation/prediction/power/supply/sector/{sector}`

Returns a simulated power supply for a specific sector.

Parameters

Name	Type	Example	Description
<i>version</i>	String	v0.1	The version of the API to use.
<i>trial</i>	String	Terni	The trial infrastructure to use for invoking the respective service.
<i>sector</i>	String	INDUSTRIAL	The sector to fetch the predictions for.

The class diagram of the response (instance of PredictionReport) has been already presented in Figure 37, page 146.

2.13.4.1 Retrieve a report related to the predicted sector power supply [GET]

Request

- Headers
 1. x-auth-token: `an_auth_token`
 2. Accept: `application/json`

Response 200 (application/json)

• Body

```
1. {
2.   "metadata":{
3.     "api_version":"0.1",
4.     "trial":"Terni",
5.     "created":"2015-01-22T11:51:09+02:00",
6.     "updated":"2015-01-22T11:51:09+02:00"
7.   },
8.   "predictions":[
9.     {
10.      "id":"INDUSTRIAL",
11.      "measurement_type":"PowerSupplyGrid",
12.      "values":[
13.        {
14.          "id":null,
15.          "datetime":"2015-01-21T10:16:27+02:00",
16.          "value":0.0
17.        },
18.        {
19.          "id":null,
20.          "datetime":"2015-01-21T12:16:27+02:00",
21.          "value":0.0
22.        },
23.        {
24.          "id":null,
25.          "datetime":"2015-01-21T15:16:27+02:00",
26.          "value":0.0
27.        },
28.        {
29.          "id":null,
30.          "datetime":"2015-01-21T21:16:27+02:00",
31.          "value":0.0
32.        },
33.        {
34.          "id":null,
35.          "datetime":"2015-01-22T09:16:27+02:00",
36.          "value":0.0
37.        }
38.      ],
39.      "start_time":null,
40.      "end_time":null
41.    }
42.  ]
43. }
```

2.14 Smart Factories

This set of APIs offers information related to the monitoring and control of equipment of a smart factory.

2.14.1 Get available machines

Endpoint URL: `[/{version}/{trial}/factory/equipment/machines]`

Gets the list of available machines of the factory.

Parameters

Name	Type	Example	Description
<i>version</i>	String	v0.1	The version of the API to use.
<i>trial</i>	String	Aachen	The trial infrastructure to use for invoking the respective service.

The class diagram of the response (instance of MachinesReport) is given in Figure 38.

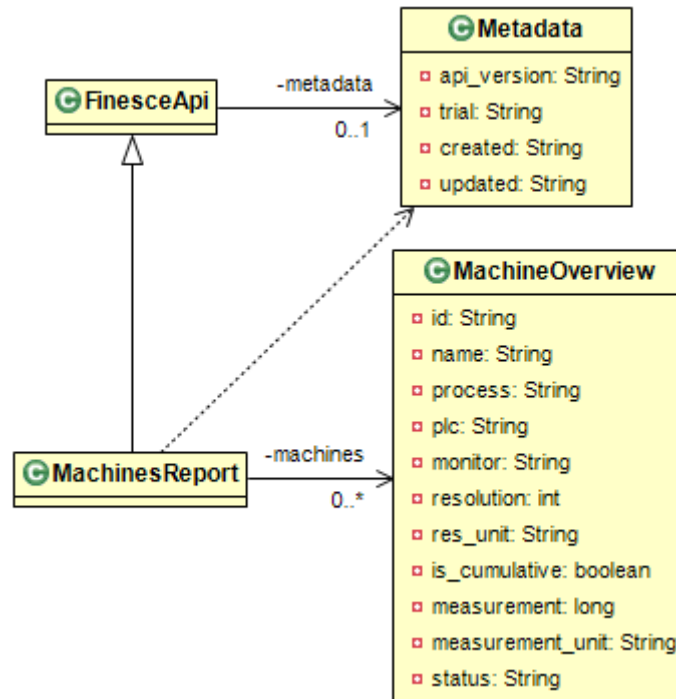

Figure 38: Class diagram of a MachinesReport response.

The attributes of the relevant response are detailed in the tables following.

Table 67: Attributes of the MachinesReport class

Name	Type	Description
metadata	Metadata	The metadata of the report (see Table 5, page 15)
machines	List<MachineOverview>	The list of machine details of the trial (see Table 68, page 152)

Table 68: Attributes of the MachineOverview class

Name	Type	Description
------	------	-------------

id	String	The id of the machine
name	String	The name of the machine
process	String	The process the machine is currently into
plc	String	The PLC id of the machine
monitor	String	The type of the meter monitoring the machine
resolution	Integer	The period of the measurements
res_unit	String	The unit of the resolution (e.g. minutes)
is_cumulative	Boolean	Indicates whether the measurement is cumulative
measurement	long	The actual measurement
measurement_unit	String	The measurement unit
status	String	The status of the machine

2.14.1.1 Retrieve the list of available machines [GET]

Response 200 (application/json)

- Body

```

1. {
2.   "metadata":{
3.     "api_version":"0.1",
4.     "trial":"Aachen",
5.     "created":"2014-12-30T19:02:41+02:00",
6.     "updated":"2014-12-30T19:02:41+02:00"
7.   },
8.   "machines":[
9.     {
10.      "id":"Machine-1",
11.      "name":"Factory Building Lateral",
12.      "process":"none",
13.      "plc":"none",
14.      "monitor":"SmartMeter (Kellendonk)",
15.      "resolution":1,
16.      "res_unit":"minute",
17.      "is_cumulative":true,
18.      "measurement":18661250,
19.      "measurement_unit":"kWh",
20.      "status":"operating"
21.    },
22.    {
23.      "id":"Machine-172",
24.      "name":"Manual assembly stations",
25.      "process":"Assembly",
26.      "plc":"none",
27.      "monitor":"Secondary Distributor",
28.      "resolution":15,
29.      "res_unit":"minute",
30.      "is_cumulative":false,
31.      "measurement":9990,
32.      "measurement_unit":"kWh",
33.      "status":"operating"
34.    }
35.  ]
36. }
```

2.14.2 Get information over a single machine

Endpoint URL: `[/]{version}/{trial}/factory/equipment/machines/{machine_id}`

Gets detailed, historical information regarding a single machine, based on its id.

Parameters

Name	Type	Example	Description
version	String	v0.1	The version of the API to use.
trial	String	Aachen	The trial infrastructure to use for invoking the respective service.
machine_id	String	Machine-1	The id of the machine of interest.

The class diagram of the response (instance of SingleMachineReport) is given in Figure 39: Class diagram of a SingleMachineReport response. Figure 39.

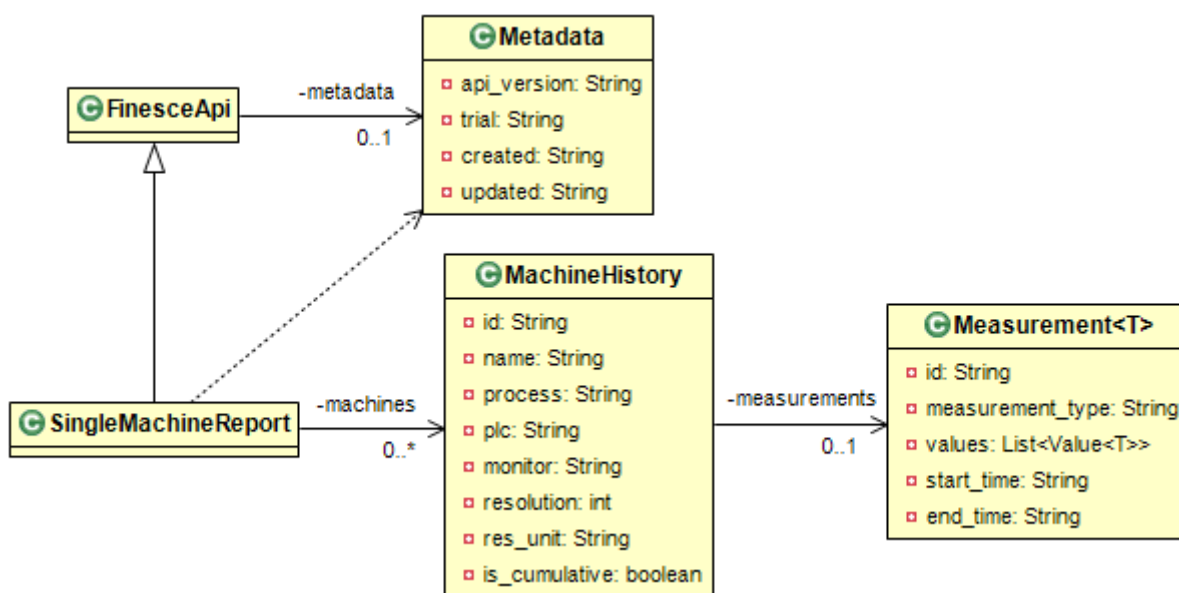

Figure 39: Class diagram of a SingleMachineReport response.

The attributes of the relevant response are detailed in the tables following.

Table 69: Attributes of the SingleMachineReport class

Name	Type	Description
metadata	Metadata	The metadata of the report (see Table 5, page 15)
machines	List<MachineHistory>	The list of the machine details of interest (only one machine details object is included, see

Table 70: Attributes of the MachineHistory class

Name	Type	Description
id	String	The id of the machine
name	String	The name of the machine
process	String	The process the machine is currently into
plc	String	The PLC id of the machine
monitor	String	The type of the meter monitoring the machine
resolution	Integer	The period of the measurements
res_unit	String	The unit of the resolution (e.g. minutes)
is_cumulative	Boolean	Indicates whether the measurement is cumulative
measurements	List<Measurement<EnergyStatusSingleton>>	The list of measurements of the machine (see Table 14, page 28)

Note that the EnergyStatusSingleton measurement type is more complex than the usual measurement types supported (e.g. EnergyConsumptionGrid etc) which usually follow a more common format. In an attempt to fully and exhaustively analyse the SingleMachineReport class hierarchy, Figure 40 would be of merit.

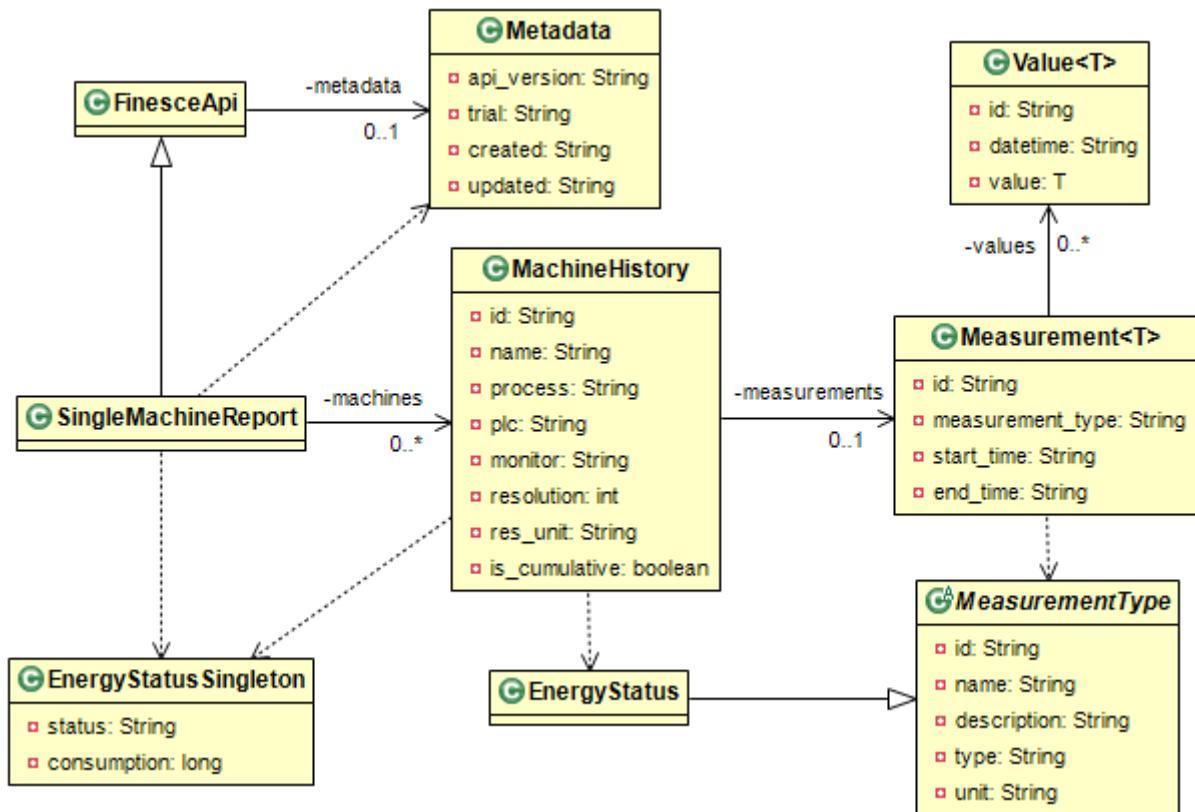

Figure 40: Class diagram of a SingleMachineReport response (full depth analysis).

2.14.2.1 Retrieve historical measurements for a single machine [GET]

Response 200 (application/json)

- Body

```

1. {
2.   "metadata":{
3.     "api_version":"0.1",
4.     "trial":"Aachen",
5.     "created":"2015-01-12T16:10:02+01:00",
6.     "updated":"2015-01-12T16:10:02+01:00"
7.   },
8.   "machine":[
9.     {
10.      "id":"Machine-1",
11.      "name":"Factory Building Lateral",
12.      "process":"none",
13.      "plc":"none",
14.      "monitor":"SmartMeter (Kellendonk)",
15.      "resolution":1,

```

```
16.         "res_unit": "minute",
17.         "is_cumulative": true,
18.         "measurements": {
19.             "measurement_type": "EnergyStatus",
20.             "values": [
21.                 {
22.                     "id": null,
23.                     "datetime": "2015-01-12T16:10:02+01:00",
24.                     "value": {
25.                         "status": "operating",
26.                         "consumption": 18661248
27.                     }
28.                 },
29.                 {
30.                     "id": null,
31.                     "datetime": "2015-01-12T16:11:02+01:00",
32.                     "value": {
33.                         "status": "operating",
34.                         "consumption": 18661250
35.                     }
36.                 }
37.             ]
38.         }
39.     }
40. ]
41. }
```

2.15 Virtual Power Plant

This set of APIs offers information regarding the operation of Virtual Power Plants (VPP).

2.15.1 Get VPP components data

Endpoint URL: [/{version}/{trial}/vpp/components]

Gets the available components of the VPP. Currently, 'Aachen' is the only trial offering this service.

Parameters

Name	Type	Example	Description
version	String	v0.1	The version of the API to use.
trial	String	Aachen	The trial infrastructure to use for invoking the respective service.

The class diagram of the response (instance of ComponentsReport) is given in Figure 41.

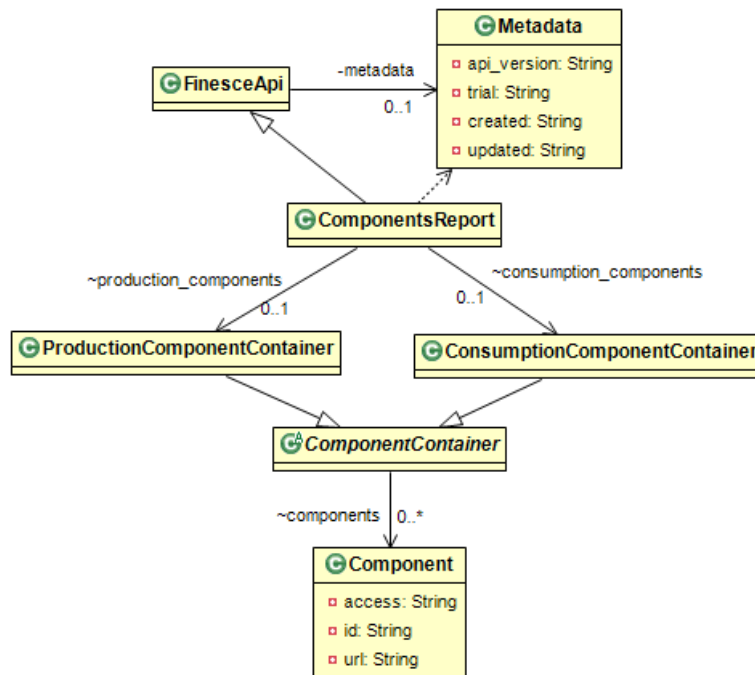

Figure 41: Class diagram of a ComponentsReport response

The attributes of the relevant response class are detailed in the tables following.

Table 71: Attributes of the ComponentsReport class

Name	Type	Description
metadata	Metadata	The metadata of the report (see Table 5, page 15)
production_components	ProductionComponentContainer	A container for the production components of the VPP (extends ComponentContainer, see Table 72, page 158)
consumption_components	ConsumptionComponentContainer	A container for the consumption components of the VPP (extends ComponentContainer, see Table 72, page 158)

ComponentContainer, see
Table 72, page 158)

Table 72: Attributes of the ComponentContainer class

Name	Type	Description
components	List<Component>	The list of components of interest (see Table 73, page 158)

Table 73: Attributes of the Component class

Name	Type	Description
access	String	The access permissions of the component
id	String	The id of the component
url	String	The URL of the component data

2.15.1.1 Retrieve VPP components [GET]

Request

- Headers
 1. x-auth-token: `an_auth_token`
 2. Accept: `application/json`

Response 200 (application/json)

- Body
 1. {
 2. "metadata":{
 3. "api_version":"0.1",
 4. "trial":"Aachen",
 5. "created":"2014-12-30T19:21:59+02:00",
 6. "updated":"2014-12-30T19:21:59+02:00"
 7. },
 8. "consumption_components":{
 9. "components":[
 10. {
 11. "access":"rw",
 12. "id":"machine_1",
 13. "url":"https://130.206.82.22/finesce/api/v0.1/Aachen/vpp/consumption/machine_1/data"
 14. },
 15. {
 16. "access":"rw",
 17. "id":"machine_2",
 18. "url":"https://130.206.82.22/finesce/api/v0.1/Aachen/vpp/consumption/machine_2/data"
 19. }
 20.]
 21. },
 22. "production_components":{
 23. "components":[
 24. {
 25. "access":"rw",
 26. "id":"biogas_1",
 27. "url":"https://130.206.82.22/finesce/api/v0.1/Aachen/vpp/production/biogas_1/data"

```

28.         },
29.         {
30.             "access": "rw",
31.             "id": "biogas_2",
32.             "url": "https://130.206.82.22/finesce/api/v0.1/Aachen/v
pp/production/biogas_2/data"
33.         },
34.         {
35.             "access": "rw",
36.             "id": "biogas_2",
37.             "url": "https://130.206.82.22/finesce/api/v0.1/Aachen/v
pp/production/biogas_3/data"
38.         }
39.     ]
40. }
41. }

```

2.15.2 Get the data of a specific VPP component

Endpoint URL: `[/{version}/{trial}/vpp/{comp_type}/{comp_id}/data]`

Gets the list of dates of available data for a component. The {comp_type} can be either 'production' or 'consumption'. A valid {comp_id} can be found from the `[/{version}/{trial}/vpp/components]` service. Currently, 'Aachen' is the only trial offering this service.

Parameters

Name	Type	Example	Description
<i>version</i>	String	v0.1	The version of the API to use.
<i>trial</i>	String	Aachen	The trial infrastructure to use for invoking the respective service.
<i>comp_id</i>	String	machine_1	The component type (can be either 'production' or 'consumption').

The class diagram of the response (instance of ComponentDataReport) is given in Figure 42.

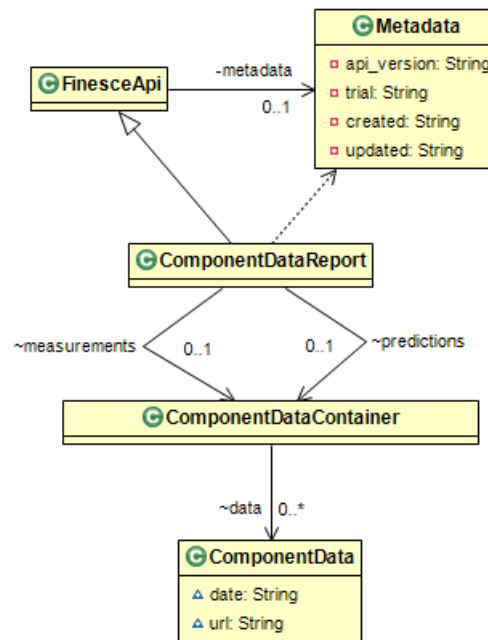

Figure 42: Class diagram of a ComponentDataReport

The attributes of the relevant response class are detailed in the tables following.

Table 74: Attributes of the ComponentDataReport class

Name	Type	Description
metadata	Metadata	The metadata of the report (see Table 5, page 15)
measurements	ComponentDataContainer	A container for the production components of the VPP (see Table 75, page 160)
predictions	ComponentDataContainer	A container for the consumption components of the VPP (see Table 75, page 160)

Table 75: Attributes of the ComponentDataContainer class

Name	Type	Description
data	List<ComponentData>	The list of dates holding data to show (see Table 76, page 160)

Table 76: Attributes of the ComponentData class

Name	Type	Description
date	String	The date with the data of interest (a full day)
url	String	The URL of the service for the actual data measurements

2.15.2.1 Retrieve data for a VPP component [GET]

Request

- Headers
 1. x-auth-token: `an_auth_token`
 2. Accept: `application/json`

Response 200 (application/json)

- Body

```

1. {
2.   "metadata":{
3.     "api_version":"0.1",
4.     "trial":"Aachen",
5.     "created":"2014-12-30T19:28:57+02:00",
6.     "updated":"2014-12-30T19:28:57+02:00"
7.   },
8.   "predictions":{
9.     "data":[
10.      {
11.        "date":"2014-12-20",
12.        "url":"https://130.206.82.22/finesce/api/v0.1/Aachen/v
pp/consumption/machine_1/predictions/2014-12-21"
13.      },
14.      {
15.        "date":"2014-12-20",
16.        "url":"https://130.206.82.22/finesce/api/v0.1/Aachen/v
pp/consumption/machine_1/predictions/2014-12-22"
17.      }
18.    ]
19.   },
20.   "measurements":{
21.     "data":[
22.      {
23.        "date":"2014-12-19",
24.        "url":"https://130.206.82.22/finesce/api/v0.1/Aachen/v
pp/consumption/machine_1/measurements/2014-12-19"
25.      },
26.      {
27.        "date":"2014-12-20",
28.        "url":"https://130.206.82.22/finesce/api/v0.1/Aachen/v
pp/consumption/machine_1/measurements/2014-12-20"
29.      }
30.    ]
31.   }
32. }

```

2.15.3 Get the measurements of a specific VPP component in a day

Endpoint URL: `[/{version}/{trial}/vpp/{comp_type}/{comp_id}/measurements/{date}]`

Gets measurement data for component for a specified data and data type. The {comp_type} can be either 'production' or 'consumption'. A valid {comp_id} can be found from the `[/{version}/{trial}/vpp/components` service. A valid {date} can be found from the `[/{version}/{trial}/vpp/{comp_type}/{comp_id}/data` service. Currently, 'Aachen' is the only trial offering this service.

Parameters

Name	Type	Example	Description
<i>version</i>	String	v0.1	The version of the API to use.
<i>trial</i>	String	Aachen	The trial infrastructure to use for invoking the respective service.
<i>comp_type</i>	String	consumption	The component type (can be either 'production' or 'consumption').
<i>comp_id</i>	String	machine_1	The id of the component to check.
<i>date</i>	String	2014-12-19	The date for which to check for measurements.

The class diagram of the response (instance of MeasurementReport) has been already presented in Figure 10, page 28.

2.15.3.1 Retrieve VPP component measurements [GET]**Request**

- Headers
 1. x-auth-token: `an_auth_token`
 2. Accept: `application/json`

Response 200 (application/json)

- Body
 1. {
 2. "metadata":{
 3. "api_version":"0.1",
 4. "trial":"Aachen",
 5. "created":"2015-01-12T16:11:31+01:00",
 6. "updated":"2015-01-12T16:11:31+01:00"
 7. },
 8. "measurements":{
 9. "measurement_type":"EnergyConsumptionGrid",
 10. "values":[
 11. {
 12. "id":null,
 13. "datetime":"2014-12-19T00:00:00+01:00",
 14. "value":1299.6427241955832
 15. },
 16. {
 17. "id":null,
 18. "datetime":"2014-12-19T00:15:00+01:00",
 19. "value":1211.496413801941
 20. },
 21. . . .
 22. {
 23. "id":null,
 24. "datetime":"2014-12-19T23:30:00+01:00",
 25. "value":1276.5377229188848
 26. },
 27. {

```

28.         "id":null,
29.         "datetime":"2014-12-19T23:45:00+01:00",
30.         "value":1183.4397883717554
31.     }
32. ],
33.     "start_time":null,
34.     "end_time":null
35. }
36. }

```

2.15.4 Get the predictions for a specific VPP component in a day

Endpoint URL: `[/{version}/{trial}/vpp/{comp_type}/{comp_id}/predictions/{date}]`

Gets prediction data for component for a specified data and data type. The {comp_type} can be either 'production' or 'consumption'. A valid {comp_id} can be found from the `[/{version}/{trial}/vpp/components]` service. A valid {date} can be found from the `[/{version}/{trial}/vpp/{comp_type}/{comp_id}/data]` service. Currently, 'Aachen' is the only trial offering this service.

Parameters

Name	Type	Example	Description
<i>version</i>	String	v0.1	The version of the API to use.
<i>trial</i>	String	Aachen	The trial infrastructure to use for invoking the respective service.
<i>comp_type</i>	String	consumption	The component type (can be either 'production' or 'consumption').
<i>comp_id</i>	String	machine_1	The id of the component to check.
<i>date</i>	String	2014-12-19	The date for which to check for measurements.

The class diagram of the response (instance of PredictionReport) has been already presented in Figure 37, page 146.

2.15.4.1 Retrieve VPP component predictions [GET]

Request

- Headers
 1. x-auth-token: `an_auth_token`
 2. Accept: `application/json`

Response 200 (application/json)

- Body
 1. {
 2. "metadata":{
 3. "api_version":"0.1",
 4. "trial":"Aachen",
 5. "created":"2015-01-12T16:12:46+01:00",
 6. "updated":"2015-01-12T16:12:46+01:00"
 7. },

```
8.   "predictions":{
9.     "measurement_type":"EnergyConsumptionGrid",
10.    "values":[
11.      {
12.        "id":null,
13.        "datetime":"2014-12-21T00:00:00+01:00",
14.        "value":1108.2871315269886
15.      },
16.      {
17.        "id":null,
18.        "datetime":"2014-12-21T00:15:00+01:00",
19.        "value":1236.4299327191509
20.      },
21.      . . .
22.      {
23.        "id":null,
24.        "datetime":"2014-12-21T23:30:00+01:00",
25.        "value":1090.2929825964893
26.      },
27.      {
28.        "id":null,
29.        "datetime":"2014-12-21T23:45:00+01:00",
30.        "value":1192.6908303176292
31.      }
32.    ],
33.    "start_time":null,
34.    "end_time":null
35.  }
36. }
```

2.16 Weather forecast

This API is responsible for fetching information related to the weather be it in the past or the near future.

2.16.1 Get available forecast descriptors

Endpoint URL: [/{version}/{trial}/weather/available_descriptors]

Delivers the available forecast descriptors of the specified trial infrastructure. 'Terni', 'Madrid' and 'Malmo' are the only trials providing this service.

Parameters

Name	Type	Example	Description
version	String	v0.1	The version of the API to use.
trial	String	Terni	The trial infrastructure to use for invoking the respective service.

The class diagram of the response (instance of WeatherAvailableOptions) is given in Figure 43.

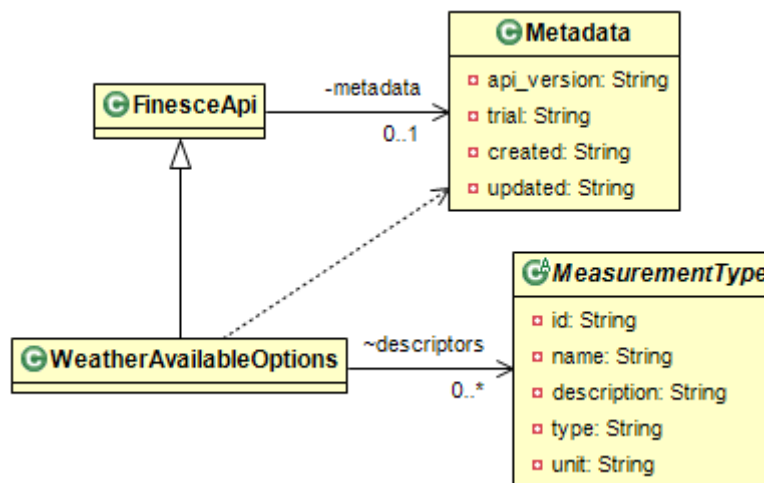

Figure 43: Class diagram of a WeatherAvailableOptions response.

The attributes of the relevant response class are detailed in the table following.

Table 77: Attributes of TH WeatherAvailableOptions class.

Name	Type	Description
metadata	Metadata	The metadata of the report (see Table 5, page 15)
descriptors	List<MeasurementType>	The list of descriptors available to/by the trial (see Table 12, page 24)

In essence, a descriptor is nothing more than a weather-related measurement type.

2.16.1.1 Retrieve the available weather descriptors [GET]

Request

- Headers
 1. x-auth-token: `an_auth_token`
 2. Accept: `application/json`

Response 200 (application/json)

- Body
 1. {
 2. "metadata":{
 3. "api_version":"0.1",
 4. "trial":"Terni",
 5. "created":"2015-01-15T20:27:26+01:00",
 6. "updated":"2015-01-15T20:27:26+01:00"
 7. },
 8. "descriptors":[
 9. {
 10. "id":null,
 11. "name":"Temperature",
 12. "description":"The instantaneous actual/forecasted temperature (outside)",
 13. "type":"Weather",
 14. "unit":"C"
 15. },
 16. {
 17. "id":null,
 18. "name":"MaxTemperature",
 19. "description":"The maximum temperature observed/forecasted",
 20. "type":"Weather",
 21. "unit":"C"
 22. },
 23. {
 24. "id":null,
 25. "name":"MinTemperature",
 26. "description":"The maximum temperature observed/forecasted",
 27. "type":"Weather",
 28. "unit":"C"
 29. },
 30. {
 31. "id":null,
 32. "name":"CloudCover",
 33. "description":"The fraction of the sky obscured by clouds"
 34. "type":"Weather",
 35. "unit":"-"
 36. },
 37. {
 38. "id":null,
 39. "name":"WindSpeed",
 40. "description":"The instantaneous actual/forecasted wind speed",
 41. "type":"Speed",
 42. "unit":"kmph"
 43. },
 44. {
 45. "id":null,
 46. "name":"SunriseTime",

```

47.         "description": "The time when the sun is forecasted to rise
48.     ",
49.         "type": "Weather",
50.         "unit": "Time in iso8601 CET"
51.     },
52.     {
53.         "id": null,
54.         "name": "SunsetTime",
55.         "description": "The time when the sun is forecasted to set"
56.     },
57.     {
58.         "type": "Time",
59.         "unit": "Time in iso8601 CET"
60.     }
61. ]
62. }
    
```

2.16.2 Get detailed weather report

Endpoint URL: [/{version}/{trial}/weather/{from}/{to}]

A weather report for a specific area, in a specific period of time. Valid {from} and {to} values are expressed in ISO8601 format. 'Terni' and 'Malmo' are the only trials providing this service.

Parameters

Name	Type	Example	Description
version	String	v0.1	The version of the API to use.
trial	String	Terni	The trial infrastructure to use for invoking the respective service.
from	String	2014-12-20T02:15:00+02:00	The lower limit of the duration of the query, in an ISO8601 compliant format
to	String	2014-12-20T03:15:00+02:00	The upper limit of the duration of the query, in an ISO8601 compliant format

The class diagram of the response (instance of WeatherDetails) is given in Figure 44.

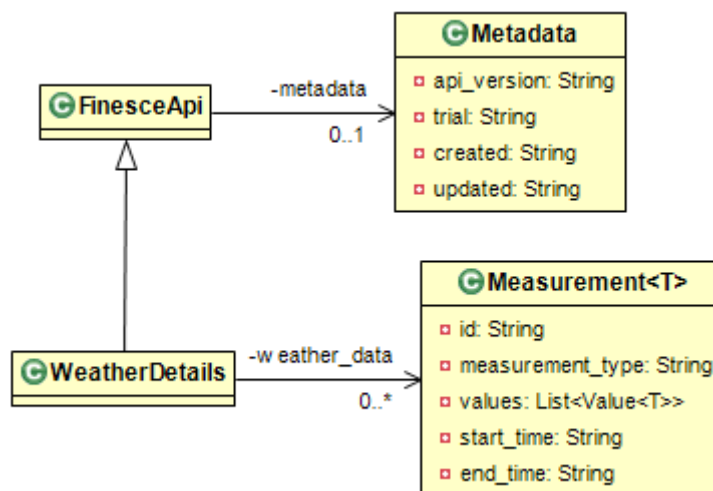

Figure 44: Class diagram of a WeatherDetails response

The attributes of the relevant response are detailed in the following table.

Table 78: Attributes of the WeatherDetails class

Name	Type	Description
metadata	Metadata	The metadata of the report (see Table 5, page 15)
weather_data	Measurement<T>	The weather details (see Figure 10, page 28)

2.16.2.1 Retrieve a weather report [GET]

Request

- Headers
 1. x-auth-token: `an_auth_token`
 2. Accept: `application/json`

Response 200 (application/json)

- Body
 1. {
 2. "metadata":{
 3. "api_version":"0.1",
 4. "trial":"Terni",
 5. "created":"2015-01-15T20:25:20+01:00",
 6. "updated":"2015-01-15T20:25:20+01:00"
 7. },
 8. "weather_data":[
 9. {
 10. "measurement_type":"Temperature",
 11. "values":[
 12. {
 13. "id":null,
 14. "datetime":"2015-01-20T01:30:20+01:00",
 15. "value":7.33
 16. },
 17. {
 18. "id":null,
 19. "datetime":"2015-01-20T01:45:20+01:00",
 20. "value":7.33
 21. },
 22. {
 23. "id":null,
 24. "datetime":"2015-01-20T02:00:20+01:00",
 25. "value":7.13
 26. },
 27. {
 28. "id":null,
 29. "datetime":"2015-01-20T02:15:20+01:00",
 30. "value":6.96
 31. }
 32.]
 33. },
 34. {
 35. "measurement_type":"MaxTemperature",
 36. "values":[
 37. {
 38. "id":null,

```
39.         "datetime":"2015-01-20T01:30:20+01:00",
40.         "value":13.91
41.     },
42.     {
43.         "id":null,
44.         "datetime":"2015-01-20T01:45:20+01:00",
45.         "value":13.91
46.     },
47.     {
48.         "id":null,
49.         "datetime":"2015-01-20T02:00:20+01:00",
50.         "value":13.92
51.     },
52.     {
53.         "id":null,
54.         "datetime":"2015-01-20T02:15:20+01:00",
55.         "value":13.92
56.     }
57. ]
58. },
59. {
60.     "measurement_type":"MinTemperature",
61.     "values":[
62.         {
63.             "id":null,
64.             "datetime":"2015-01-20T01:30:20+01:00",
65.             "value":4.92
66.         },
67.         {
68.             "id":null,
69.             "datetime":"2015-01-20T01:45:20+01:00",
70.             "value":4.99
71.         },
72.         {
73.             "id":null,
74.             "datetime":"2015-01-20T02:00:20+01:00",
75.             "value":4.96
76.         },
77.         {
78.             "id":null,
79.             "datetime":"2015-01-20T02:15:20+01:00",
80.             "value":4.96
81.         }
82.     ]
83. },
84. {
85.     "measurement_type":"CloudCover",
86.     "values":[
87.         {
88.             "id":null,
89.             "datetime":"2015-01-20T01:30:20+01:00",
90.             "value":0.04
91.         },
92.         {
93.             "id":null,
94.             "datetime":"2015-01-20T01:45:20+01:00",
95.             "value":0.06
96.         },
97.         {
98.             "id":null,
99.             "datetime":"2015-01-20T02:00:20+01:00",
```

```
100.         "value":0.08
101.     },
102.     {
103.         "id":null,
104.         "datetime":"2015-01-20T02:15:20+01:00",
105.         "value":0.11
106.     }
107. ]
108. },
109. {
110.     "measurement_type":"WindSpeed",
111.     "values":[
112.         {
113.             "id":null,
114.             "datetime":"2015-01-20T01:30:20+01:00",
115.             "value":0.0
116.         },
117.         {
118.             "id":null,
119.             "datetime":"2015-01-20T01:45:20+01:00",
120.             "value":0.0
121.         },
122.         {
123.             "id":null,
124.             "datetime":"2015-01-20T02:00:20+01:00",
125.             "value":0.0
126.         },
127.         {
128.             "id":null,
129.             "datetime":"2015-01-20T02:15:20+01:00",
130.             "value":0.0
131.         }
132.     ]
133. },
134. {
135.     "measurement_type":"SunriseTime",
136.     "values":[
137.         {
138.             "id":null,
139.             "datetime":"2015-01-20T01:30:20+01:00",
140.             "value":"2014-12-20T07:36:37+01:00"
141.         },
142.         {
143.             "id":null,
144.             "datetime":"2015-01-20T01:45:20+01:00",
145.             "value":"2014-12-20T07:36:37+01:00"
146.         },
147.         {
148.             "id":null,
149.             "datetime":"2015-01-20T02:00:20+01:00",
150.             "value":"2014-12-20T07:36:37+01:00"
151.         },
152.         {
153.             "id":null,
154.             "datetime":"2015-01-20T02:15:20+01:00",
155.             "value":"2014-12-20T07:36:37+01:00"
156.         }
157.     ]
158. },
159. {
160.     "measurement_type":"SunsetTime",
```

```

161.         "values":[
162.             {
163.                 "id":null,
164.                 "datetime":"2015-01-20T01:30:20+01:00",
165.                 "value":"2014-12-20T16:39:36+01:00"
166.             },
167.             {
168.                 "id":null,
169.                 "datetime":"2015-01-20T01:45:20+01:00",
170.                 "value":"2014-12-20T16:39:36+01:00"
171.             },
172.             {
173.                 "id":null,
174.                 "datetime":"2015-01-20T02:00:20+01:00",
175.                 "value":"2014-12-20T16:39:36+01:00"
176.             },
177.             {
178.                 "id":null,
179.                 "datetime":"2015-01-20T02:15:20+01:00",
180.                 "value":"2014-12-20T16:39:36+01:00"
181.             }
182.         ]
183.     }
184. ]
185. }

```

2.16.3 Get detailed weather report

Endpoint URL: `[/{version}/{trial}/weather/{weather_descriptor}/{from}/{to}]`

A weather report (only one weather descriptor) for a specific time frame. Valid `{weather_descriptor}` values can be derived by calling the `/{version}/{trial}/weather/available_descriptors` service. Valid `{from}` and `{to}` values are expressed in ISO8601 format. 'Terni', 'Mardid' and 'Malmo' are the trials offering this service.

Parameters

Name	Type	Example	Description
<i>version</i>	String	v0.1	The version of the API to use.
<i>trial</i>	String	Terni	The trial infrastructure to use for invoking the respective service.
<i>weather_descriptor</i>	String	temperature	The type of forecast descriptor to get weather data for
<i>from</i>	String	2014-12-20T02:15:00+02:00	The lower limit of the duration of the query, in an ISO8601 compliant format
<i>to</i>	String	2014-12-20T03:15:00+02:00	The upper limit of the duration of the query, in an ISO8601 compliant format

The class diagram of the response (instance of WeatherDetails) has been already provided in Figure 44, page 167.

2.16.3.1 Retrieve a weather report [GET]

Request

- Headers
 1. x-auth-token: `an_auth_token`
 2. Accept: `application/json`

Response 200 (application/json)

- Body
 1. {
 2. "metadata":{
 3. "api_version":"0.1",
 4. "trial":"Terni",
 5. "created":"2015-01-16T15:11:18+02:00",
 6. "updated":"2015-01-16T15:11:18+02:00"
 7. },
 8. "weather_data":[
 9. {
 10. "measurement_type":"Temperature",
 11. "values":[
 12. {
 13. "id":null,
 14. "datetime":"2014-12-20T01:30:00+02:00",
 15. "value":7.33
 16. },
 17. {
 18. "id":null,
 19. "datetime":"2014-12-20T01:45:00+02:00",
 20. "value":7.33
 21. },
 22. {
 23. "id":null,
 24. "datetime":"2014-12-20T02:00:00+02:00",
 25. "value":7.13
 26. },
 27. {
 28. "id":null,
 29. "datetime":"2014-12-20T02:15:00+02:00",
 30. "value":6.96
 31. }
 32.]
 33. }
 34.]
 35. }

2.16.4 Get detailed weather report (limited records)

Endpoint URL:

`/{version}/{trial}/weather/{weather_descriptor}/{from}/{to}/{measurements_number}`

A weather report (only one weather descriptor) for a specific time frame. Valid {weather_descriptor} values can be derived by calling the `/{version}/{trial}/weather/`

available_descriptors service. Valid {from} and {to} values are expressed in ISO8601 format. 'Madrid' is the only trial offering this service.

Parameters

Name	Type	Example	Description
version	String	v0.1	The version of the API to use.
trial	String	Terni	The trial infrastructure to use for invoking the respective service.
weather_descriptor	String	Temperature	The type of forecast descriptor to get weather data for
from	String	2014-12-20T02:15:00+02:00	The lower limit of the duration of the query, in an ISO8601 compliant format
to	String	2014-12-20T03:15:00+02:00	The upper limit of the duration of the query, in an ISO8601 compliant format

The class diagram of the response (instance of WeatherDetails) has been already provided in Figure 44, page 167.

2.16.4.1 Retrieve a weather report [GET]

Request

- Headers
 1. Accept: `application/json`

Response 200 (application/json)

- Body
 1. {
 2. "metadata":{
 3. "api_version":"0.1",
 4. "trial":"Madrid",
 5. "created":"2015-02-26T17:38:52+02:00",
 6. "updated":"2015-02-26T17:38:52+02:00"
 7. },
 8. "weather_data":[
 9. {
 10. "measurement_type":"Temperature",
 11. "values":[
 12. {
 13. "id":null,
 14. "datetime":"2014-12-20T01:15:00+02:00",
 15. "value":15.57227974062439

```
16.         },
17.         {
18.             "id":null,
19.             "datetime":"2014-12-20T01:27:00+02:00",
20.             "value":16.402985633903707
21.         },
22.         {
23.             "id":null,
24.             "datetime":"2014-12-20T01:39:00+02:00",
25.             "value":8.330456602614198
26.         },
27.         {
28.             "id":null,
29.             "datetime":"2014-12-20T01:51:00+02:00",
30.             "value":1.2384797645123213
31.         },
32.         {
33.             "id":null,
34.             "datetime":"2014-12-20T02:03:00+02:00",
35.             "value":0.49984188761267756
36.         },
37.         {
38.             "id":null,
39.             "datetime":"2014-12-20T02:15:00+02:00",
40.             "value":7.09751620071414
41.         }
42.     ],
43.     "start_time":"2014-12-20T01:15:00+02:00",
44.     "end_time":"2014-12-20T02:15:00+02:00"
45. }
46. ]
47. }
```

3 Conclusion

This report overviews and documents the services provided by the FINESCE trial infrastructures and offered to third parties. A classification of the various services has been performed and the common data model composing the consolidated FINESCE API specification is presented. All the services are exposed in a RESTful way, directing the documentation orientation towards a relevant way of presenting the API, including service endpoint URL breakdown via parameter explanation, presentation of service responses through class diagrams and tabulated definition of the class parameters and, finally, indicative service output examples.

In the framework of a general Smart City ecosystem fuelled by Smart Energy web services, the FINESCE API could play the role of a standard, well documented, implemented and tested interface, designed to cover a large variety of disciplines related to Smart Energy systems.

4 References

- [1] FINESCE, "<http://www.finesce.eu>," [Online].
- [2] FINESCE API Mediator DSE, "[http://finesce.github.io/DSE.html?id=FINESCE_API_Mediator_\(FAM\)_DSE](http://finesce.github.io/DSE.html?id=FINESCE_API_Mediator_(FAM)_DSE)," FINESCE, 2015. [Online].
- [3] Swagger, "<http://swagger.io>," [Online].
- [4] FINESCE API Documentation - Swagger, "<https://130.206.82.22/finesce/api/docs/index.html>," FINESCE, Feb. 2015. [Online].
- [5] FINESCE API Documentation - APIARY, "<http://docs.fam.apiary.io>," FINESCE, 28 Feb. 2015. [Online].
- [6] Creative Commons Attribution Share-Alike 4.0 (cc-by-sa), "<http://creativecommons.org/licenses/by-sa/4.0/legalcode>," [Online].

5 List of Abbreviations

API	Application Programming Interface
DSM	Demand Side Management
EVSE	Electric Vehicle Supply Equipment
FI	Future Internet
FI-PPP	Future Internet Public Private Partnership
FINESCE	Future INtErnet Smart Utility ServiCEs
IP	Incentive Plan
IRP	Issue Resolution Plan
VPP	Virtual Power Plan

6 Appendix A – Summary of the FINESCE API services exposed by the FINESCE API Mediator

6.1 Aachen Trial – Smart Factory

Method	Service URL	Page
GET	/Aachen/factory/equipment/machines	152
GET	/Aachen/factory/equipment/machines/{machine_id}	153

6.2 Aachen Trial – Virtual Power Plant

Method	Service URL	Page
POST	/Aachen/tokens	17
GET	/Aachen/vpp/components	157
GET	/Aachen/vpp/{comp_type}/{comp_id}/data	159
GET	/Aachen/vpp/{comp_type}/{comp_id}/measurements/{date}	161
GET	/Aachen/vpp/{comp_type}/{comp_id}/predictions/{date}	163

6.3 Horsens Trial

Method	Service URL	Page
POST	/Horsens/tokens	17
POST	/Horsens/tokens/refresh	18
GET	/Horsens/buildings	20
GET	/Horsens/buildings/{id}	22
GET	/Horsens/buildings/{id}/measurement_types	23
GET	/Horsens/buildings/measurement_types	24
GET	/Horsens/buildings/measurement_types/id/{id}	25
GET	/Horsens/buildings/measurement_types/type/{type}	26
GET	/Horsens/buildings/{id}/measurements/{type_id}/{from}/{to}	27
GET	/Horsens/vehicles	76
GET	/Horsens/vehicles/{id}	77
GET	/Horsens/vehicles/{id}/measurement_types	81
GET	/Horsens/vehicles/measurement_types	78
GET	/Horsens/vehicles/measurement_types/id/{id}	80
GET	/Horsens/vehicles/measurement_types/type/{type}	81
GET	/Horsens/vehicles/{id}/measurements/{type_id}/{from}/{to}	82

6.4 Ireland Trial

Method	Service URL	Page
POST	/Ireland/tokens	17
POST	/Ireland/tokens/refresh	18
GET	/Ireland/algoweights	117
GET	/Ireland/algoweights/{id}	118

GET	/Ireland/charging_modes	89
GET	/Ireland/charging_modes/{id}	91
GET	/Ireland/charging_modes/{id}/evses	92
GET	/Ireland/charging_modes/{id}/evtypes	94
GET	/Ireland/charging_states	94
GET	/Ireland/charging_states/{id}	96
GET	/Ireland/connection_states	101
GET	/Ireland/connection_states/{id}	102
GET	/Ireland/connections	97
GET	/Ireland/connections/{id}	98
GET	/Ireland/connections/{id}/charging_mode	99
GET	/Ireland/connections/{id}/connection_state	100
GET	/Ireland/energy/regional	139
GET	/Ireland/energy/regional/avg	143
GET	/Ireland/energy/regional/avg/{id}	144
GET	/Ireland/energy/regional/{id}	141
GET	/Ireland/energy/regional/{id}/region	142
GET	/Ireland/energy/regional/{id}/timeslot	142
GET	/Ireland/regions	133
GET	/Ireland/regions/{id}	134
GET	/Ireland/regions/{id}/algoweights	135
GET	/Ireland/regions/{id}/energy	136
GET	/Ireland/regions/{id}/energy/avg	137
GET	/Ireland/regions/{id}/supply_equipment	138
GET	/Ireland/supply_equipment	103
GET	/Ireland/supply_equipment/{id}	104
GET	/Ireland/supply_equipment/{id}/charging_modes	105
GET	/Ireland/supply_equipment/{id}/connections	106
GET	/Ireland/timeslots	55
GET	/Ireland/timeslots/{id}	56
GET	/Ireland/timeslots/{id}/algoweights	57
GET	/Ireland/timeslots/{id}/charging_states	59
GET	/Ireland/timeslots/{id}/energy/regional	61
GET	/Ireland/vehicle_types	86
GET	/Ireland/vehicle_types/{id}	87
GET	/Ireland/vehicle_types/{id}/vehicles	88
GET	/Ireland/vehicles/	76
GET	/Ireland/vehicles/{id}	77
GET	/Ireland/vehicles/{id}/connections	84

6.5 Madrid Trial

Method	Service URL	Page
GET	/Madrid/buildings/{id}/modules	30
GET	/Madrid/buildings/{id}/modules/{module_type}{module_id}/status/{date}	31

GET	/Madrid/buildings/{id}/modules/inverter/*/PowerMixed/{date}	73
GET	/Madrid/buildings/{id}/modules/pv/*/PowerSupply/{date}	74
GET	/Madrid/buildings/{id}/zones/{date}	32
GET	/Madrid/buildings/{id}/zones/{zone_id}/{measurement_type}/{date}	34
GET	/Madrid/weather/available_descriptors	165
GET	/Madrid/weather/{descriptor}/{from}/{to}	167
GET	/Madrid/weather/{descriptor}/{from}/{to}/{number_of_measurements}	172

6.6 Malmo Trial

Method	Service URL	Page
POST	/Malmo/tokens	17
GET	/Malmo/prices/locations	125
GET	/Malmo/prices/locations/data	128
GET	/Malmo/prices/locations/data/{name}	129
GET	/Malmo/prices/locations/data/{name}/values/{from}/{to}	130
GET	/Malmo/prices/locations/{name}	122
GET	/Malmo/prices/{from}/{to}	120
GET	/Malmo/prices/{name}	127
GET	/Malmo/prices/{name}/{from}/{to}	123

6.7 Terni Trial

Method	Service URL	Page
POST	/Terni/tokens	17
GET	/Terni/contracts/customer/{customer}/state/{state}	50
GET	/Terni/contracts/prices	52
GET	/Terni/contracts/state/{state}	51
GET	/Terni/dsm/ip/author/{author}	42
GET	/Terni/dsm/ip/author/{author}/state/{state}	47
GET	/Terni/dsm/ip/state/{state}	45
GET	/Terni/dsm/irp/author/{author}	36
GET	/Terni/dsm/irp/author/{author}/state/{state}	40
GET	/Terni/dsm/irp/state/{state}	38
GET	/Terni/energy/consumption/profile/sector/{sector}/{from}/{to}	62
GET	/Terni/energy/consumption/profile/user/{customer_id}/{from}/{to}	64
GET	/Terni/energy/consumption/total/user/{customer_id}/{from}/{to}	65
GET	/Terni/energy/production/profile/sector/{sector}/{from}/{to}	68
GET	/Terni/energy/production/profile/user/{customer_id}/{from}/{to}	69
GET	/Terni/energy/production/total/user/{customer_id}/{from}/{to}	71
GET	/Terni/meters	112
GET	/Terni/meters/sectors	115
GET	/Terni/meters/{search_options}	114
GET	/Terni/power/demand/user/{customer_id}/{from}/{to}	67
GET	/Terni/power/supply/user/{customer_id}/{from}/{to}	72

<i>GET</i>	/Terni/simulation/prediction/power/demand/sector/{sector_id}	147
<i>GET</i>	/Terni/simulation/prediction/power/demand/user/{customer_id}	146
<i>GET</i>	/Terni/simulation/prediction/power/supply/sector/{sector_id}	150
<i>GET</i>	/Terni/simulation/prediction/power/supply/user/{customer_id}	149
<i>GET</i>	/Terni/social	108
<i>GET</i>	/Terni/social/{events_number}	110
<i>GET</i>	/Terni/weather/available_descriptors	165
<i>GET</i>	/Terni/weather/{descriptor}/{from}/{to}	167
<i>GET</i>	/Terni/weather/{from}/{to}	171